



CHAPTER FOUR

CIRCUIT THEOREMS

4.1 INTRODUCTION

The growth in areas of application of electric circuits has led to an evolution from simple to complex circuits. To handle the complexity, engineers over the years have developed some theorems to simplify circuit analysis. Such theorems include Thevenin's and Norton's theorems. Since these theorems are applicable to **linear circuits**, we first discuss the concept of circuit linearity. In addition to circuit theorems, we discuss the concepts of **superposition, maximum power transfer, Millman's theorem, Substitution theorem, and Reciprocity theorem** in this chapter.

4.2 LINEARITY PROPERTY

Linearity is the property of an element describing a linear relationship between cause and effect. The property is a combination of both the homogeneity property and the additivity property.

The homogeneity property requires that if the input (also called the excitation) is multiplied by a constant, then the output (also called the response) is multiplied by the same constant. For a resistor, for example, Ohm's law relates the input \mathbf{i} to the output \mathbf{v} ,

$$\mathbf{v} = \mathbf{iR} \quad (4.1)$$

If the current is increased by a constant \mathbf{k} , then the voltage increases correspondingly by \mathbf{k} , that is,

$$\mathbf{k}\mathbf{iR} = \mathbf{k}\mathbf{v} \quad (4.2)$$

The additivity property requires that the response to a sum of inputs is the sum of the responses to each input applied separately. Using the relationship of a resistor, if

$$\mathbf{v}_1 = \mathbf{i}_1\mathbf{R} \quad \text{and} \quad \mathbf{v}_2 = \mathbf{i}_2\mathbf{R} \quad (4.3)$$

then applying $(\mathbf{i}_1 + \mathbf{i}_2)$ gives

$$\mathbf{v} = (\mathbf{i}_1 + \mathbf{i}_2)\mathbf{R} = \mathbf{i}_1\mathbf{R} + \mathbf{i}_2\mathbf{R} = \mathbf{v}_1 + \mathbf{v}_2 \quad (4.4)$$

A linear circuit is one whose output is linearly related (or directly proportional) to its input.

Example 4.1: For the circuit in **Fig. 4.1**, find \mathbf{i}_0 when $\mathbf{v}_s = 12\text{ V}$ and $\mathbf{v}_s = 24\text{ V}$.

Solution: Applying **KVL** to the two loops, we obtain

$$12\mathbf{i}_1 - 4\mathbf{i}_2 + \mathbf{v}_s = 0 \quad (4.1.1)$$

$$-4\mathbf{i}_1 + 16\mathbf{i}_2 - 3\mathbf{v}_x - \mathbf{v}_s = 0 \quad (4.1.2)$$

But $v_x = 2i_1$. Equation (4.1.2) becomes

$$-10i_1 + 16i_2 - v_s = 0 \quad (4.1.3)$$

Adding Eqs. (4.1.1) and (4.1.3) yields

$$2i_1 + 12i_2 = 0 \Rightarrow i_1 = -6i_2$$

Substituting this in Eq. (4.1.1), we get

$$-76i_2 + v_s = 0 \Rightarrow i_2 = v_s/76$$

When $v_s = 12 \text{ V}$, $i_o = i_2 = 12/76 \text{ A}$

When $v_s = 24 \text{ V}$, $i_o = i_2 = 24/76 \text{ A}$

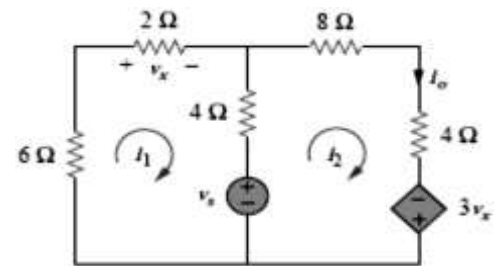
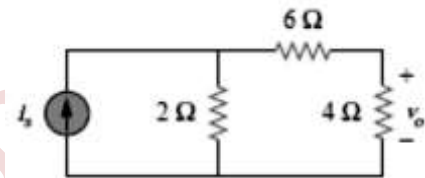

Figure 4.1 For Example 4.1.

Practice problems:

1-For the circuit in Figure below, find v_o when $i_s = 15$ and $i_s = 30 \text{ A}$.

Answer: 10 V, 20 V.



4.3 SUPERPOSITION

The idea of superposition rests on the linearity property.

The superposition principle states that the voltage across (or current through) an element in a linear circuit is the algebraic sum of the voltages across (or currents through) that element due to each independent source acting alone.

However, to apply the superposition principle, we must keep two things in mind:

1. We consider one independent source at a time while all other independent sources are turned off. This implies that we replace every voltage source by 0 V (or a short circuit), and every current source by 0 A (or an open circuit).
2. Dependent sources are left intact because they are controlled by circuit variables. With these in mind, we apply the superposition principle in three steps:

Steps to Apply Super position Principle:

1. Turn off all independent sources except one source. Find the output (voltage or current) due to that active source using nodal or mesh analysis.
2. Repeat step 1 for each of the other independent sources.
3. Find the total contribution by adding algebraically all the contributions due to the independent sources.

Analyzing a circuit using superposition has one major disadvantage: it may very likely involve more work. Keep in mind that superposition is based on linearity.

Example 4.2: Use the superposition theorem to find v in the circuit in Fig. 4.2.

Solution:

Since there are two sources, let

$$v = v_1 + v_2$$

where v_1 and v_2 are the contributions due to the 6-V voltage source and the 3-A current source, respectively. To obtain v_1 , we set the current source to zero, as shown in Fig. 4.3(a).

Applying KVL to the loop in Fig. 4.3(a) gives

$$12i_1 - 6 = 0 \Rightarrow i_1 = 0.5 \text{ A}$$

Thus,

$$v_1 = 4i_1 = 2 \text{ V}$$

We may also use voltage division to get v_1 by writing

$$v_1 = \frac{4}{4+8}(6) = 2 \text{ V}$$

To get v_2 , we set the voltage source to zero, as in Fig. 4.3(b).

Using current division,

$$i_3 = \frac{8}{4+8}(3) = 2 \text{ A}$$

Hence, $v_2 = 4i_3 = 8 \text{ V}$

And we find $v = v_1 + v_2 = 2 + 8 = 10 \text{ V}$

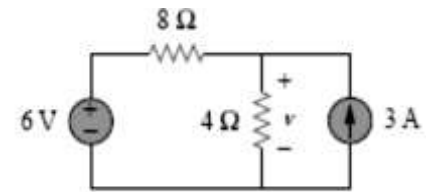

Figure 4.2 For Example 4.2.

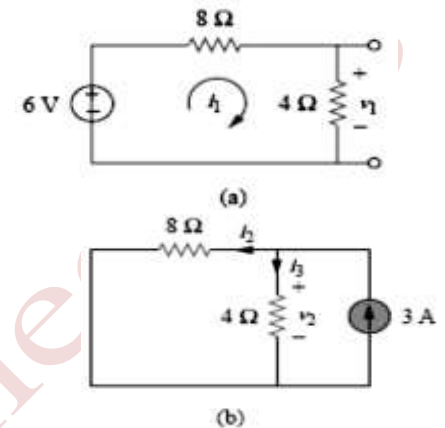
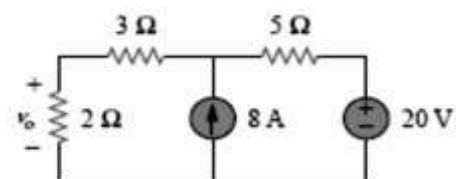

Figure 4.3 For Example 4.2:
 (a) calculating v_1 , (b) calculating v_2 .

Practice problems:

1-Using the superposition theorem, find v_o in the circuit in Figure below.

Answer: 12 V.



2- Use superposition to obtain v_x in the circuit of Figure below.

Answer: 0.75 A.

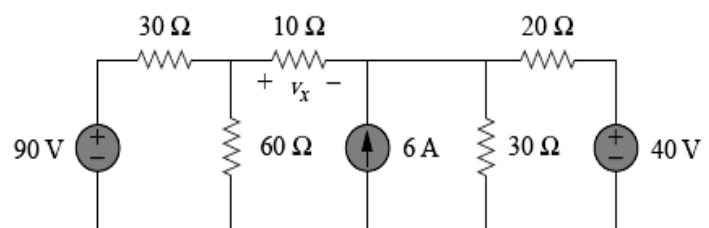

4.4 SOURCE TRANSFORMATION

We have noticed that series-parallel combination and wye-delta transformation help simplify circuits. Source transformation is another tool for simplifying circuits. We can substitute a voltage source in series with a resistor for a current source in parallel with a resistor, or vice versa, as shown in **Fig. 4.4**. Either substitution is known as a *source transformation*.

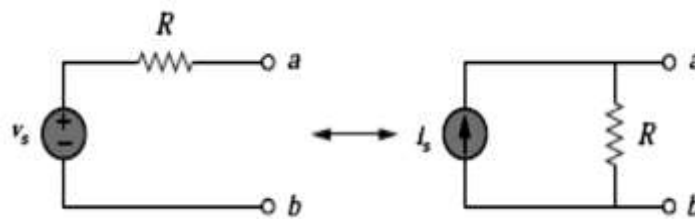

Figure 4.4 Transformation of independent sources.

Key Point: A source transformation is the process of replacing a voltage source v_s in series with a resistor R by a current source i_s in parallel with a resistor R , or vice versa.

We need to find the relationship between v_s and i_s that guarantees the two configurations in **Fig. 4.4** are equivalent with respect to nodes **a, b**.

Suppose R_L is connected between nodes **a, b** in **Fig. 4.4(a)**. Using Ohms law, the current in R_L is.

$$i_L = \frac{v_s}{(R+R_L)} \quad \text{R and } R_L \text{ in series} \quad (4.5)$$

If it is to be replaced by a current source then load current must be $\frac{v}{(R+R_L)}$

Now suppose the same resistor R_L , is connected between nodes **a, b** in **Fig. 4.4 (b)**. Using current division, the current in R_L , is

$$i_L = i_s \frac{R}{(R+R_L)} \quad (4.6)$$

If the two circuits in **Fig. 4.4** are equivalent, these resistor currents must be the same. Equating the right-hand sides of **Eqs.4.5** and **4.6** and simplifying

$$i_s = \frac{v_s}{R} \quad \text{or} \quad v_s = i_s R \quad (4.7)$$

Source transformation also applies to dependent sources, provided we carefully handle the dependent variable. As shown in **Fig. 4.5**, a dependent voltage source in series with a resistor can be transformed to a dependent current source in parallel with the resistor or vice versa.

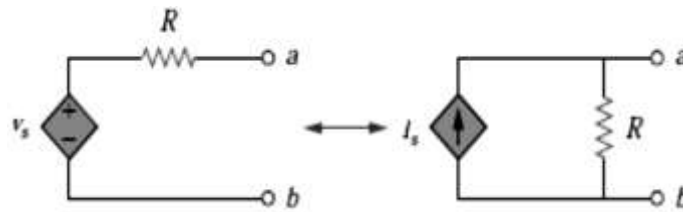

Figure 4.5 Transformation of dependent sources.

However, we should keep the following points in mind when dealing with source transformation.

1. Note from Fig. 4.4 (or Fig. 4.5) that the arrow of the current source is directed toward the positive terminal of the voltage source.
2. Note from Eq. (4.7) that source transformation is not possible when $R = 0$, which is the case with an ideal voltage source. However, for a practical, nonideal voltage source, $R \neq 0$. Similarly, an ideal current source with $R = \infty$ cannot be replaced by a finite voltage source.

Example 4.3: Use source transformation to find v_o in the circuit in Fig. 4.6.

Solution:

We first transform the current and voltage sources to obtain the circuit in Fig. 4.7(a). Combining the 4- Ω and 2- Ω resistors in series and transforming the 12-V voltage source gives us Fig. 4.7(b). We now combine the 3- Ω and 6- Ω resistors in parallel to get 2- Ω . We also combine the 2-A and 4-A current sources to get a 2-A source. Thus, by repeatedly applying source transformations, we obtain the circuit in Fig. 4.7 (c).

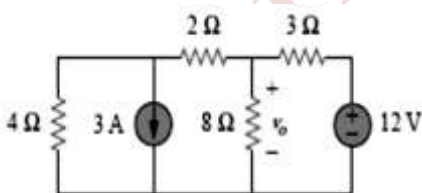

Figure 4.6

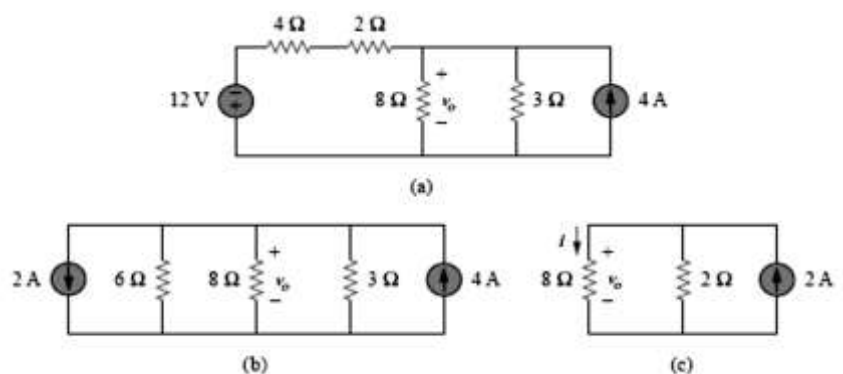

Figure 4.7

Alternatively, since the 8- Ω and 2- Ω resistors in Fig. 4.7(c) are in parallel, they have the same voltage v_o across them. Hence,

$$v_o = (8 \parallel 2)(2 \text{ A}) = \frac{8 \times 2}{10} (2) = 3.2 \text{ V}$$

Practice problems:

1-Find i_o in the circuit shown below using source transformation.

Answer: 1.78 A.

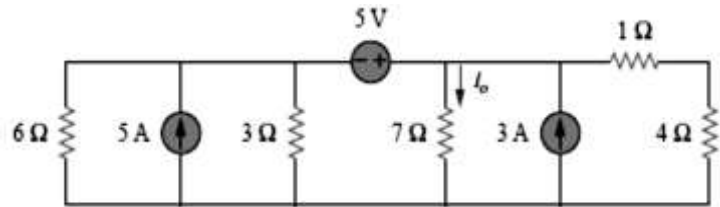

4.5 THEVENIN'S THEOREM

It often occurs in practice that a particular element in a circuit is variable (usually called the load) while other elements are fixed. As a typical example, a household outlet terminal may be connected to different appliances constituting a variable load. Each time the variable element is changed, the entire circuit has to be analyzed all over again. To avoid this problem, Thevenin's theorem provides a technique by which the fixed part of the circuit is replaced by an equivalent circuit.

According to Thevenin's theorem, the linear circuit in Fig. 4.8(a) can be replaced by that in Fig. 4.8(b) is known as the Thevenin equivalent circuit; it was developed in 1883 by M. Leon Thevenin (1857–1926), a French telegraph engineer.

Thevenin's theorem states that a linear two-terminal circuit can be replaced by an equivalent circuit consisting of a voltage source V_{Th} in series with a resistor R_{Th} , where V_{Th} is the open-circuit voltage at the terminals and R_{Th} is the input or equivalent resistance at the terminals when the independent sources are turned off.

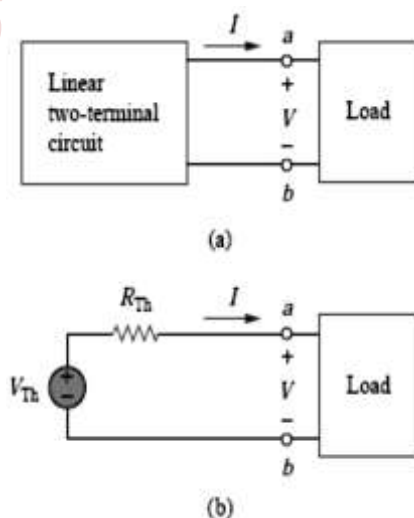

Figure 4.8 Replacing a linear two-terminal circuit by its Thevenin equivalent: (a) original circuit, (b) the Thevenin equivalent circuit.

To find the Thevenin equivalent voltage V_{Th} and resistance R_{Th} , suppose the two circuits in Fig. 4.8 are equivalent. the open-circuit voltage across the terminals a-b in Fig. 4.8(a) must be equal to the voltage source V_{Th} in Fig. 4.8(b), since the two circuits are equivalent. Thus V_{Th} is the open-circuit voltage across the terminals as shown in Fig. 4.9(a); that is,

$$V_{Th} = v_{oc} \tag{4.8}$$

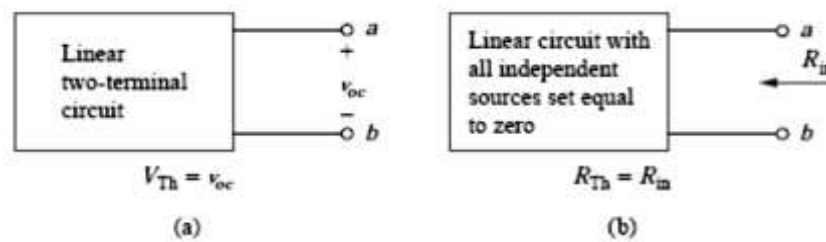

Figure 4.9 Finding V_{Th} and R_{Th} .

R_{Th} is the input resistance at the terminals when the independent sources are turned off, as shown in Fig. 4.9(b); that is,

$$R_{Th} = R_{in} \quad (4.9)$$

To apply this idea in finding the Thevenin resistance R_{Th} , we need to consider two cases.

CASE 1: If the network has no dependent sources, we turn off all independent sources. R_{Th} is the input resistance of the network looking between terminals **a** and **b**, as shown in Fig. 4.9(b).

CASE 2: If the network has dependent sources, we turn off all independent sources. As with superposition, dependent sources are not to be turned off because they are controlled by circuit variables. We apply a voltage source v_o at terminals **a** and **b** and determine the resulting current i_o . Then $R_{Th} = v_o/i_o$, as shown in Fig. 4.10(a). Alternatively, we may insert a current source i_o at terminals **a-b** as shown in Fig. 4.10(b) and find the terminal voltage v_o . Again $R_{Th} = v_o/i_o$. Either of the two approaches will give the same result. In either approach we may assume any value of v_o and i_o . For example, we may use $v_o = 1$ V or $i_o = 1$ A, or even use unspecified values of v_o or i_o .

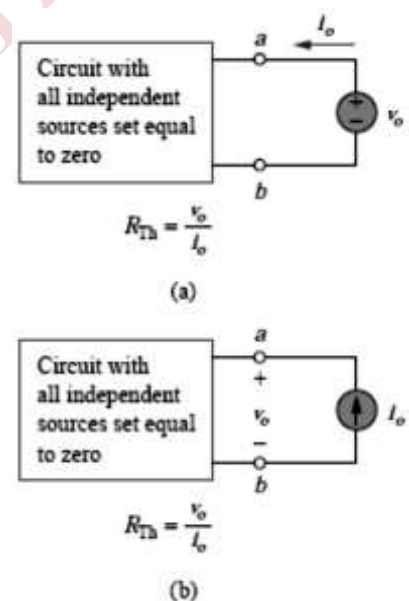

Figure 4.10 Finding R_{Th} when circuit has dependent sources.

It often occurs that R_{Th} takes a negative value. In this case, the negative resistance ($v = -iR$) implies that the circuit is supplying power. This is possible in a circuit with dependent sources.

The current I_L through the load and the voltage V_L across the load are easily determined once the Thevenin equivalent of the circuit at the load's terminals is obtained, as shown in Fig. 4.11(b). From Fig. 4.11(b), we obtain

$$I_L = \frac{V_{Th}}{R_{Th} + R_L} \quad (4.10a)$$

$$V_L = R_L I_L = \frac{R_L}{R_{Th} + R_L} V_{Th} \quad (4.10b)$$

Note from **Fig. 4.11(b)** that the Thevenin equivalent is a simple voltage divider, yielding V_L by mere inspection.

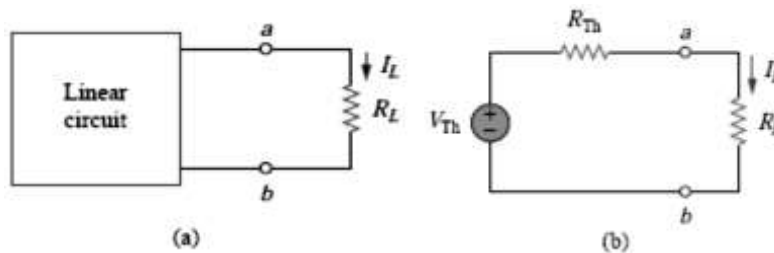

Figure 4.11 A circuit with a load : (a) original circuit, (b) Thevenin equivalent.

Example 4.4: Find the Thevenin equivalent circuit of the circuit shown in **Fig. 4.12**, to the left of the terminals a-b. Then find the current through $R_L = 6, 16,$ and 36Ω .

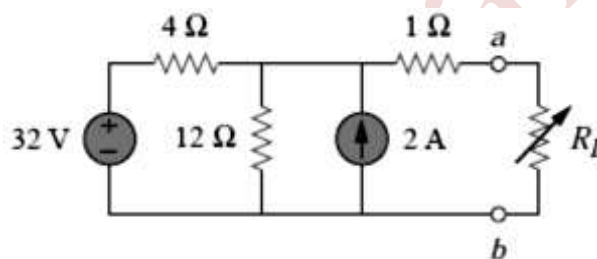

Figure 4.12 For Example 4.4.

Solution:

We find R_{Th} by turning off the 32-V voltage source (replacing it with a short circuit) and the 2-A current source (replacing it with an open circuit). The circuit becomes what is shown in **Fig. 4.13(a)**. Thus,

$$R_{Th} = 4 \parallel 12 + 1 = \frac{4 \times 12}{16} + 1 = 4 \Omega$$

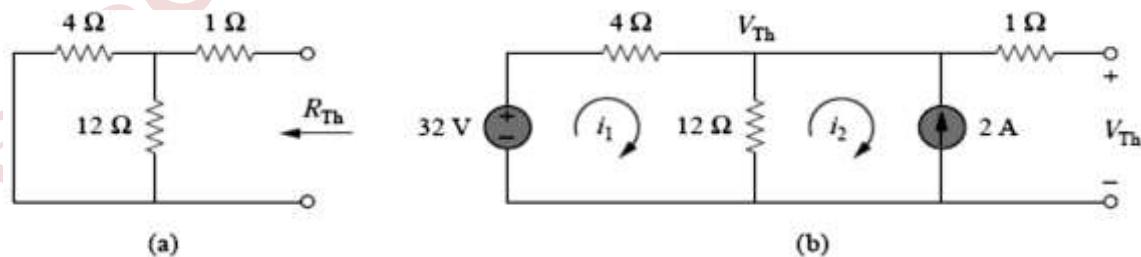

Figure 4.13 For Example 4.4: (a) finding R_{Th} , (b) finding V_{Th} .

To find V_{Th} , consider the circuit in **Fig. 4.13(b)**. Applying mesh analysis to the two loops, we obtain

$$-32 + 4i_1 + 12(i_1 - i_2) = 0, \quad i_2 = -2 \text{ A}$$

Solving for i_1 , we get $i_1 = 0.5 \text{ A}$. Thus,

$$V_{Th} = 12(i_1 - i_2) = 12(0.5 + 2.0) = 30 \text{ V}$$

The Thevenin equivalent circuit is shown in Fig. 4.14. The current through R_L is

$$I_L = \frac{V_{Th}}{R_{Th} + R_L} = \frac{30}{4 + R_L}$$

When $R_L = 6$, $I_L = \frac{30}{10} = 3 \text{ A}$

When $R_L = 16$, $I_L = \frac{30}{20} = 1.5 \text{ A}$

When $R_L = 36$, $I_L = \frac{30}{40} = 0.75 \text{ A}$

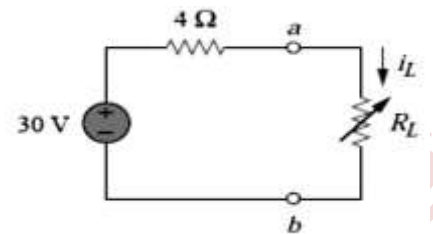
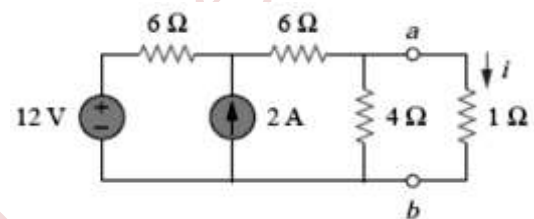

Figure 4.14 The Thevenin equivalent circuit

Practice problem: Using Thevenin's theorem, find the equivalent circuit to the left of the terminals in the circuit in Figure below. Then find i .

Answer: $V_{Th} = 6 \text{ V}$, $R_{Th} = 3 \Omega$, $i = 1.5 \text{ A}$.



4.5 NORTON'S THEOREM

In 1926, about 43 years after Thevenin published his theorem, E. L. Norton, an American engineer at Bell Telephone Laboratories, proposed a similar theorem.

Norton's theorem states that a linear two-terminal circuit can be replaced by an equivalent circuit consisting of a current source I_N in parallel with a resistor R_N , where I_N is the short-circuit current through the terminals and R_N is the input or equivalent resistance at the terminals when the independent sources are turned off.

Thus, the circuit in Fig. 4.15(a) can be replaced by the one in Fig. 4.15(b).

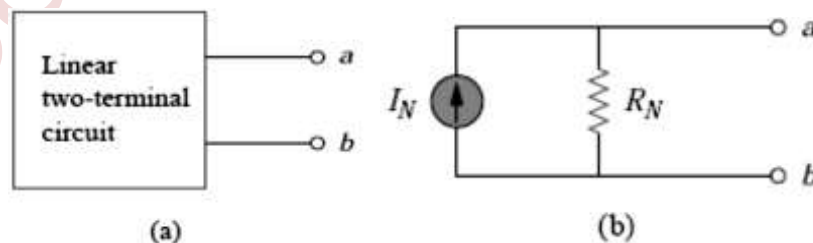

Figure 4.15 (a) Original circuit, (b) Norton equivalent circuit.

We are mainly concerned with how to get R_N and I_N . We find R_N in the same way we find R_{Th} . In fact, the Thevenin and Norton resistances are equal; that is,

$$R_N = R_{Th} \tag{4.11}$$

To find the Norton current I_N , we determine the short circuit current flowing from terminal a to b in both circuits in **Fig. 4.15**. It is evident that the short-circuit current in **Fig. 4.15(b)** is I_N . This must be the same short-circuit current from terminal a to b in **Fig. 4.15(a)**, since the two circuits are equivalent. Thus,

$$I_N = i_{sc} \quad (4.12)$$

Dependent and independent sources are treated the same way as in Thevenin's theorem. Observe the close relationship between Norton's and Thevenin's theorems: $R_N = R_{Th}$ as in **Eq. (4.11)**, and

$$I_N = \frac{V_{Th}}{R_{Th}} \quad (4.13)$$

This is essentially source transformation. For this reason, source transformation is often called Thevenin-Norton transformation.

We can calculate any two of the three using the method that takes the least effort and use them to get the third using Ohm's law. **Example 4.10** will illustrate this. Also, since

$$V_{Th} = v_{oc} \quad (4.14a)$$

$$I_N = i_{sc} \quad (4.14b)$$

$$R_{Th} = \frac{v_{oc}}{i_{sc}} = R_N \quad (4.14c)$$

the open-circuit and short-circuit tests are sufficient to find any Thevenin or Norton equivalent.

Example 4.5 Find the Norton equivalent circuit of the circuit in **Fig. 4.16**.

Solution:

We find R_N in the same way we find R_{Th} in the Thevenin equivalent circuit. Set the independent sources equal to zero. This leads to the circuit in **Fig. 4.17(a)**, from which we find R_N . Thus,

$$R_N = 5 \parallel (8 + 4 + 8) = 5 \parallel 20 = \frac{20 \times 5}{25} = 4 \Omega$$

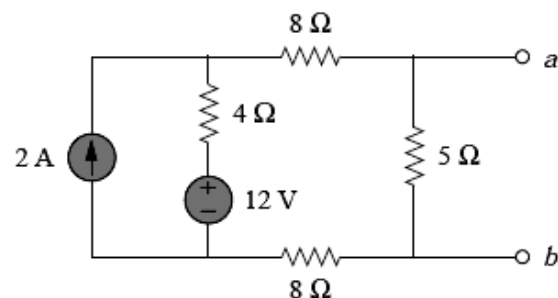

Figure 4.16 For Example 4.5.

To find I_N , we short-circuit terminals a and b, as shown in **Fig. 4.17(b)**. We ignore the 5-Ω resistor because it has been short-circuited. Applying mesh analysis, we obtain

$$i_1 = 2 \text{ A}, \quad 20i_2 - 4i_1 - 12 = 0$$

From these equations, we obtain

$$i_2 = 1 \text{ A} = i_{sc} = I_N$$

Alternatively, we may determine I_N from V_{Th}/R_{Th} . We obtain V_{Th} as the open-circuit voltage across terminals a and b in Fig. 4.17(c). Using mesh analysis, we obtain

$$i_3 = 2 \text{ A}$$

$$25i_4 - 4i_3 - 12 = 0 \Rightarrow i_4 = 0.8 \text{ A}$$

and

$$v_{oc} = V_{Th} = 5i_4 = 4 \text{ V}$$

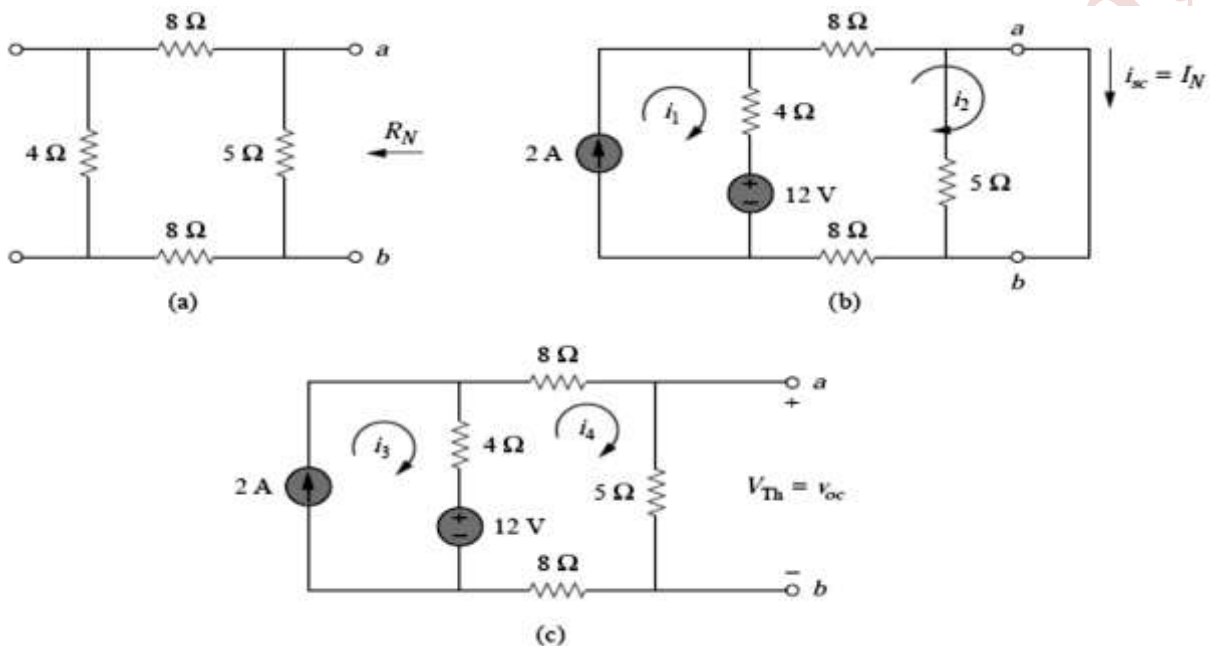

Figure 4.17 For Example 4.5; finding: (a) R_N , (b) $I_N = i_{sc}$, (c) $V_{Th} = v_{oc}$.

Hence,

$$I_N = \frac{V_{Th}}{R_{Th}} = \frac{4}{4} = 1 \text{ A}$$

as obtained previously. This also serves to confirm Eq. that $R_{Th} = v_{oc}/i_{sc} = 4/1 = 4 \Omega$. Thus, the Norton equivalent circuit is as shown in Fig. 4.18.

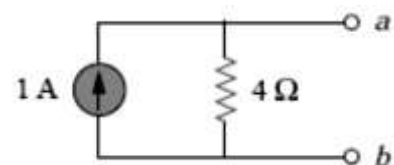
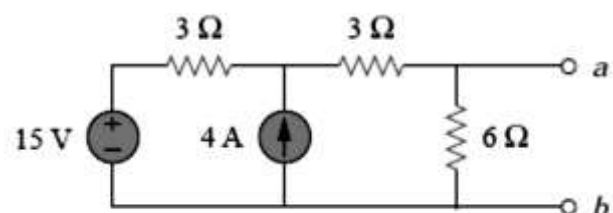

Figure 4.18 Norton equivalent of the circuit in Fig. 4.16.

Practice problem: Find the Norton equivalent circuit for the circuit in Figure below.

Answer: $R_N = 3 \Omega$, $I_N = 4.5 \text{ A}$.



4.6 MAXIMUM POWER TRANSFER

In many practical situations, a circuit is designed to provide power to a load. While for electric utilities, minimizing power losses in the process of transmission and distribution is critical for efficiency and economic reasons, there are other applications in areas such as communications where it is desirable to maximize the power delivered to a load. We now address the problem of delivering the maximum power to a load when given a system with known internal losses.

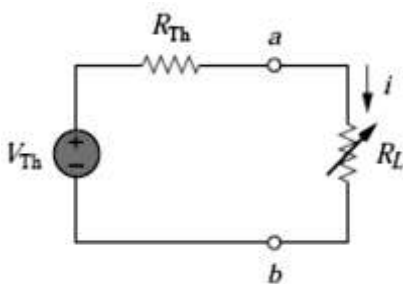

Figure 4.19 The circuit used for maximum power transfer.

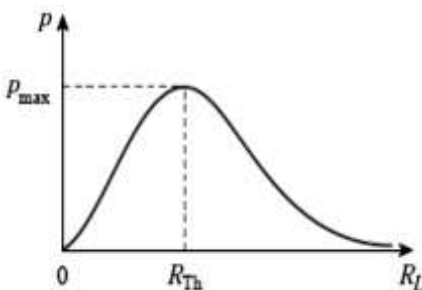

Figure 4.20 Power delivered to the load as a function of R_L

The Thevenin equivalent is useful in finding the maximum power a linear circuit can deliver to a load. We assume that we can adjust the load resistance R_L . If the entire circuit is replaced by its Thevenin equivalent except for the load, as shown in **Fig. 4.19**, the power delivered to the load is

$$p = i^2 R_L = \left(\frac{V_{Th}}{R_{Th} + R_L} \right)^2 R_L \quad (4.15)$$

For a given circuit, V_{Th} and R_{Th} are fixed. By varying the load resistance R_L , the power delivered to the load varies as sketched in **Fig. 4.20**. We notice from **Fig. 4.20** that the power is small for small or large values of R_L but maximum for some value of R_L between 0 and ∞ . We now want to show that this maximum power occurs when R_L is equal to R_{Th} . This is known as the maximum power theorem.

Maximum power is transferred to the load when the load resistance equals the Thevenin resistance as seen from the load ($R_L = R_{Th}$).

To prove the maximum power transfer theorem, we differentiate p in **Eq. (4.15)** with respect to R_L and set the result equal to zero. We obtain

$$\frac{dp}{dR_L} = V_{Th}^2 \left[\frac{(R_{Th} + R_L)^2 - 2R_L(R_{Th} + R_L)}{(R_{Th} + R_L)^4} \right] = V_{Th}^2 \left[\frac{(R_{Th} + R_L - 2R_L)}{(R_{Th} + R_L)^3} \right] = 0$$

This implies that

$$0 = (R_{Th} + R_L - 2R_L) = (R_{Th} - R_L) \quad (4.16)$$

which yields

$$R_L = R_{Th} \quad (4.17)$$

showing that the maximum power transfer takes place when the load resistance R_L equals the Thevenin resistance R_{Th} . We can readily confirm that Eq. (4.17) gives the maximum power by showing that $d^2p/dR_L^2 < 0$.

The maximum power transferred is obtained by substituting Eq. (4.17) into Eq. (4.15), for

$$p_{max} = \frac{V_{Th}^2}{4R_{Th}} \quad (4.18)$$

Equation (4.18) applies only when $R_L = R_{Th}$. When $R_L \neq R_{Th}$, we compute the power delivered to the load using Eq. (4.15).

Example 4.6: Find the value of R_L for maximum power transfer in the circuit of Fig. 4.21. Find the maximum power.

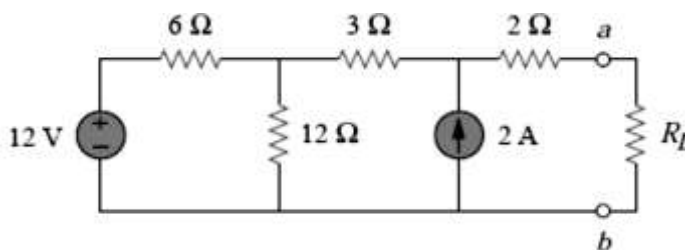

Figure 4.21 For Example 4.6.

Solution:

We need to find the Thevenin resistance R_{Th} and the Thevenin voltage V_{Th} across the terminals a-b. To get R_{Th} , we use the circuit in Fig. 4.22(a) and obtain

$$R_{Th} = 2 + 3 + 6 \parallel 12 = 5 + \frac{6 \times 12}{18} = 9 \Omega$$

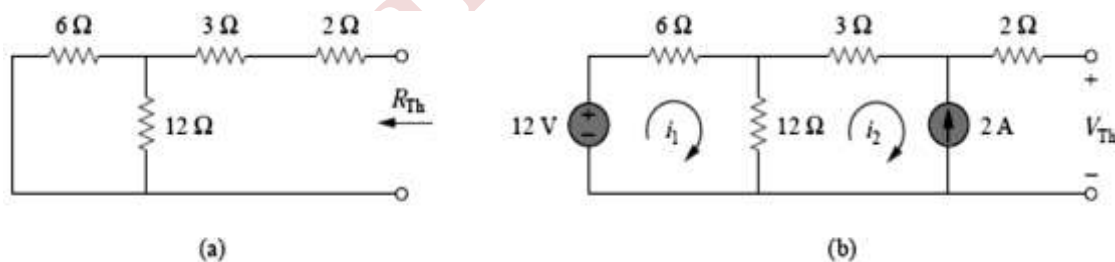

Figure 4.22 For Example 4.6: (a) finding R_{Th} , (b) finding V_{Th} .

To get V_{Th} , we consider the circuit in Fig. 4.22(b). Applying mesh analysis,

$$-12 + 18i_1 - 12i_2 = 0, \quad i_2 = -2 \text{ A}$$

Solving for i_1 , we get $i_1 = -2/3$. Applying KVL around the outer loop to get V_{Th} across terminals a-b, we obtain

$$-12 + 6i_1 + 3i_2 + 2(0) + V_{Th} = 0 \Rightarrow V_{Th} = 22 \text{ V}$$

For maximum power transfer,

$$R_L = R_{Th} = 9 \Omega$$

and the maximum power is

$$p_{max} = \frac{V_{Th}^2}{4RL} = \frac{22^2}{4 \times 9} = 13.44 \text{ W}$$

Practice problem: Determine the value of R_L that will draw the maximum power from the rest of the circuit in Figure below. Calculate the maximum power.

Answer: 4.22 Ω , 2.901 W.

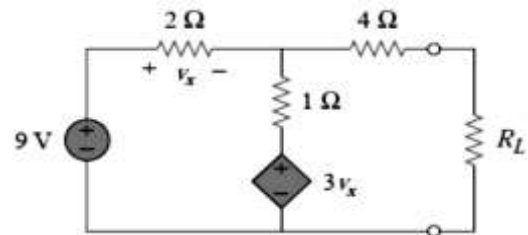

4.7 MILLMAN'S THEOREM

Through the application of Millman's theorem, any number of parallel voltage sources can be reduced to one. In Fig. 4.23, for example, the three voltage sources can be reduced to one. This would permit finding the current through or voltage across R_L without having to apply a method such as mesh analysis, nodal analysis, superposition, and so on.

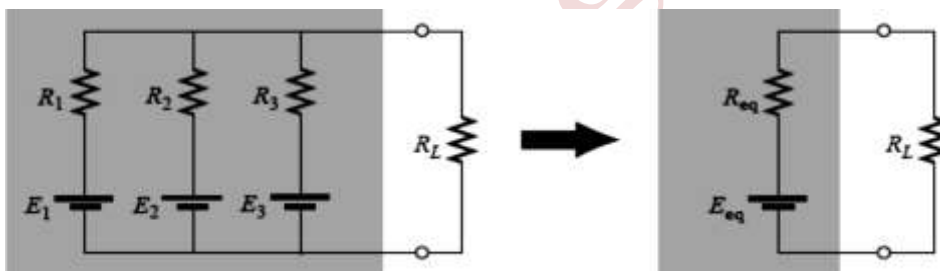

FIG. 4.23 Demonstrating the effect of applying Millman's theorem.

In general, Millman's theorem states that for any number of parallel voltage sources,

$$E_{eq} = \frac{+\frac{E_1}{R_1} \pm \frac{E_2}{R_2} \pm \frac{E_3}{R_3} \pm \dots \pm \frac{E_N}{R_N}}{\frac{1}{R_1} + \frac{1}{R_2} + \frac{1}{R_3} + \dots + \frac{1}{R_N}} \quad (4.19)$$

and

$$R_{eq} = \frac{1}{\frac{1}{R_1} + \frac{1}{R_2} + \frac{1}{R_3} + \dots + \frac{1}{R_N}} \quad (4.20)$$

Example 4.7: Using Millman's theorem, find the current through and voltage across the resistor R_L of Fig. 4.24.

Solution: By Eq. (4.19),

$$E_{eq} = \frac{+\frac{E_1}{R_1} - \frac{E_2}{R_2} + \frac{E_3}{R_3}}{\frac{1}{R_1} + \frac{1}{R_2} + \frac{1}{R_3}}$$

The minus sign is used for E_2/R_2 because that supply has the opposite polarity of the other two. The chosen reference direction is therefore that of E_1 and E_3 . The total conductance is unaffected by the direction,

And

$$E_{eq} = \frac{+\frac{10V}{5\Omega} - \frac{16V}{4\Omega} + \frac{8V}{2\Omega}}{\frac{1}{5\Omega} + \frac{1}{4\Omega} + \frac{1}{2\Omega}} = \frac{2A - 4A + 4A}{0.2S + 0.25S + 0.5S}$$

$$= \frac{2A}{0.95S} = 2.105V$$

with $R_{eq} = \frac{1}{\frac{1}{5\Omega} + \frac{1}{4\Omega} + \frac{1}{2\Omega}} = \frac{1}{0.95S} = 1.053\Omega$

The resultant source is shown in Fig. 4.25, and

$$I_L = \frac{2.105V}{1.053\Omega + 3\Omega} = \frac{2.105V}{4.053\Omega} = 0.519A$$

with $V_L = I_L R_L = (0.519A)(3\Omega) = 1.557V$

*The dual of Millman's theorem appears in Fig. 4.26. It can be shown that I_{eq} and R_{eq} , as in Fig. 4.26, are given by

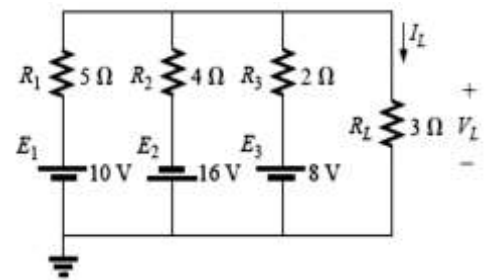

FIG. 4.24 Example 4.7.

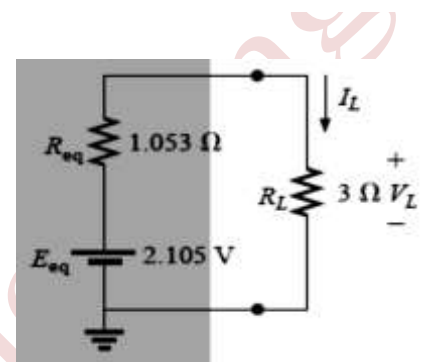

FIG. 4.25 The result of applying Millman's theorem to the network of Fig. 4.24.

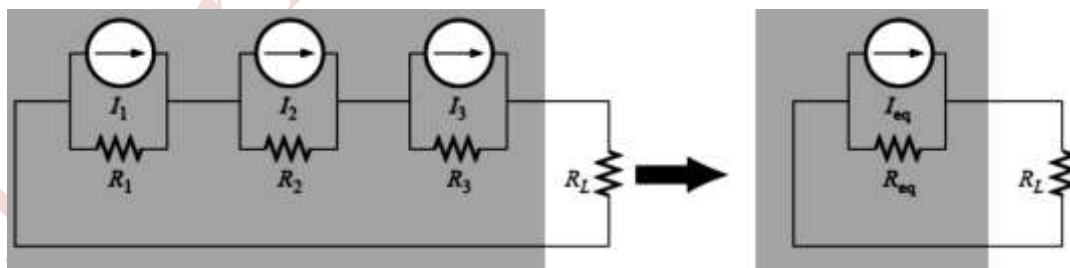

FIG. 4.26 The dual effect of Millman's theorem.

$$I_{eq} = \frac{\pm I_1 R_1 \pm I_2 R_2 \pm I_3 R_3}{R_1 + R_2 + R_3} \quad (4.21)$$

And $R_{eq} = R_1 + R_2 + R_3 \quad (4.22)$

4.8 SUBSTITUTION THEOREM

The **substitution theorem** states the following:

If the voltage across and the current through any branch of a dc bilateral network are known, this branch can be replaced by any combination of elements that will maintain the same voltage across and current through the chosen branch.

More simply, the theorem states that for branch equivalence, the terminal voltage and current must be the same. Consider the circuit of **Fig. 9.27**, in which the voltage across and current through the branch a-b are determined. Through the use of the substitution theorem, a number of equivalent a-b branches are shown in **Fig. 4.28**.

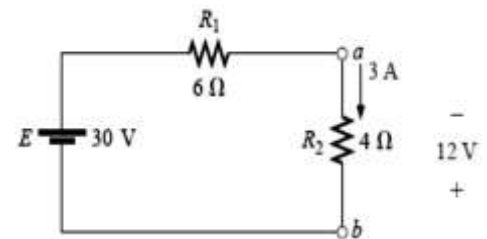

FIG. 4.27 Demonstrating the effect of the substitution theorem.

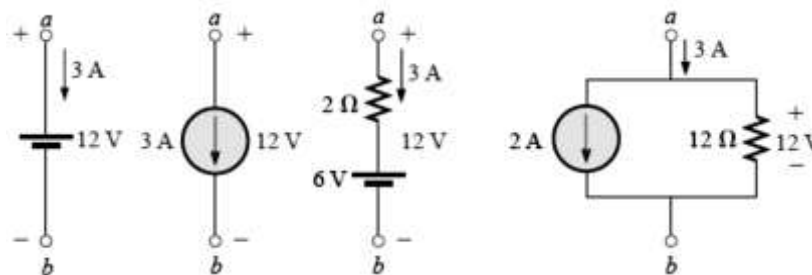

FIG. 4.28 Equivalent branches for the branch a-b of Fig. 4.27.

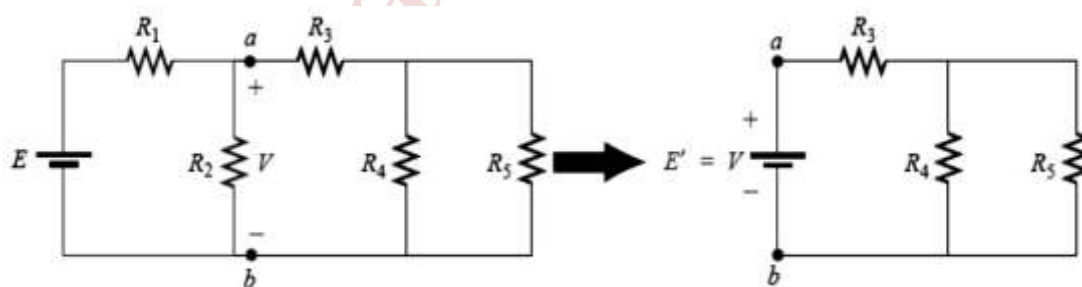

FIG. 4.29 Demonstrating the effect of knowing a voltage at some point in a complex network.

As demonstrated by the single-source equivalents of Fig. 4.28, a known potential difference and current in a network can be replaced by an ideal voltage source and current source, respectively. Understand that this theorem cannot be used to solve networks with two or more sources that are not in series or parallel. You will also recall from the discussion of bridge networks that $V = 0$ and $I = 0$ were replaced by a short circuit and an open circuit, respectively. This substitution is a very specific application of the substitution theorem.

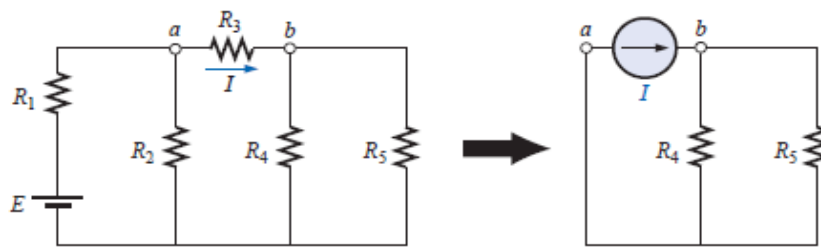

FIG. 4.30 Demonstrating the effect of knowing a current at some point in a complex network.

4.9 RECIPROCALITY THEOREM

The reciprocity theorem is applicable only to single-source networks. It is, therefore, not a theorem employed in the analysis of multisource networks described thus far. The theorem states the following:

The current I in any branch of a network, due to a single voltage source E anywhere else in the network, will equal the current through the branch in which the source was originally located if the source is placed in the branch in which the current I was originally measured.

In other words, the location of the voltage source and the resulting current may be interchanged without a change in current. The theorem requires that the polarity of the voltage source have the same correspondence with the direction of the branch current in each position. In the representative network of Fig. 4.31(a), the current I due to the voltage source E was determined. If the position of each is interchanged as shown in Fig. 4.31 (b), the current I will be the same value as indicated. To demonstrate the validity of this statement and the theorem, consider the network of Fig. 4.32, in which values for the elements of Fig. 4.31(a) have been assigned.

The total resistance is

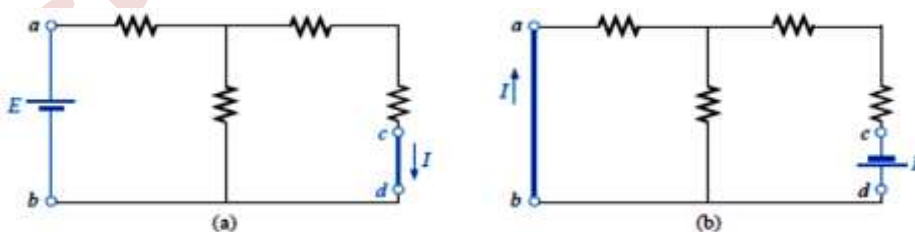

FIG. 4.31 Demonstrating the impact of the reciprocity theorem.

$$R_T = R_1 + R_2 \parallel (R_3 + R_4) = 12 \Omega + 6 \Omega \parallel (2 \Omega + 4 \Omega) = 15 \Omega$$

$$\text{and } I_S = E/R_T = 45/15 = 3 \text{ A}$$

$$\text{with } I = 3 \text{ A}/2 = 1.5 \text{ A}$$

For the network of Fig. 4.33, which corresponds to that of Fig. 4.31(b), we find

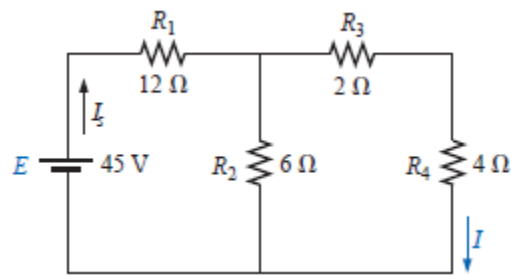

FIG. 4.32 Finding the current I due to a source E.

$$R_T = R_4 + R_3 + (R_1 \parallel R_2)$$

$$= 4 + 2 + (12 \parallel 60) = 10 \Omega$$

and $I_s = \frac{E}{R_T} = \frac{45}{10} = 4.5 \text{ A}$

so that $I = \frac{4.5 \times 6}{12 + 6} = \frac{4.5}{3} = 1.5 \text{ A}$

which agrees with the above.

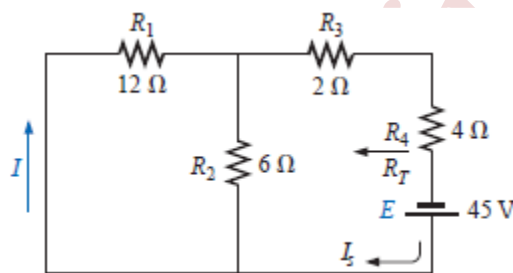

FIG. 4.33 Interchanging the location of E and I of Fig. 4.31 to demonstrate the validity of the reciprocity theorem.