

# Heat Transfer (Q) Data Sheet

## PROBLEM 1.1

The outer surface of a 0.2m-thick concrete wall is kept at a temperature of  $-5^{\circ}\text{C}$ , while the inner surface is kept at  $20^{\circ}\text{C}$ . The thermal conductivity of the concrete is  $1.2 \text{ W}/(\text{m K})$ . Determine the heat loss through a wall 10 m long and 3 m high.

## GIVEN

10 m long, 3 m high, and 0.2 m thick concrete wall  
Thermal conductivity of the concrete ( $k$ ) =  $1.2 \text{ W}/(\text{m K})$   
Temperature of the inner surface ( $T_i$ ) =  $20^{\circ}\text{C}$   
Temperature of the outer surface ( $T_o$ ) =  $-5^{\circ}\text{C}$

## FIND

The heat loss through the wall ( $q_k$ )

## ASSUMPTIONS

One dimensional heat flow  
The system has reached steady state

## SKETCH

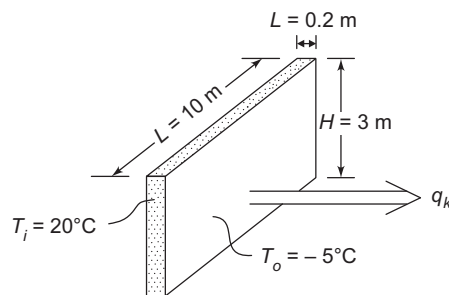

## SOLUTION

The rate of heat loss through the wall is given by Equation (1.2)

$$q_k = \frac{A K}{L} (\Delta T)$$

$$q_k = \frac{(10\text{m})(3\text{m})(1.2 \text{ W}/(\text{m K}))}{0.2 \text{ m}} (20^{\circ}\text{C} - (-5^{\circ}\text{C}))$$

$$q_k = 4500 \text{ W}$$

## COMMENTS

Since the inside surface temperature is higher than the outside temperature heat is transferred from the inside of the wall to the outside of the wall.

### PROBLEM 1.2

The weight of the insulation in a spacecraft may be more important than the space required. Show analytically that the lightest insulation for a plane wall with a specified thermal resistance is that insulation which has the smallest product of density times thermal conductivity.

#### GIVEN

Insulating a plane wall, the weight of insulation is most significant

#### FIND

Show that lightest insulation for a given thermal resistance is that insulation which has the smallest product of density ( $\rho$ ) times thermal conductivity ( $k$ )

#### ASSUMPTIONS

One dimensional heat transfer through the wall  
Steady state conditions

#### SOLUTION

The resistance of the wall ( $R_k$ ), from Equation (1.13) is

$$R_k = \frac{L}{A k}$$

where

$L$  = the thickness of the wall

$A$  = the area of the wall

The weight of the wall ( $w$ ) is

$$w = \rho A L$$

Solving this for  $L$

$$L = \frac{w}{\rho A}$$

Substituting this expression for  $L$  into the equation for the resistance

$$R_k = \frac{w}{\rho k A^2}$$
$$\therefore w = \rho k R_k A^2$$

Therefore, when the product of  $\rho k$  for a given resistance is smallest, the weight is also smallest.

#### COMMENTS

Since  $\rho$  and  $k$  are physical properties of the insulation material they cannot be varied individually. Hence in this type of design different materials must be tried to minimize the weight.

### PROBLEM 1.3

A furnace wall is to be constructed of brick having standard dimensions 22.5 cm  $\times$  11 cm  $\times$  7.5 cm. Two kinds of material are available. One has a maximum usable temperature of 1040°C and a thermal conductivity of 1.7 W/(m K), and the other has a maximum temperature limit of 870°C and a thermal conductivity of 0.85 W/(m K). The bricks cost the same and can be laid in any manner, but we wish to design the most economical wall for a furnace with a temperature on the hot side of 1040°C and on the cold side of 200°C. If the maximum amount of heat transfer permissible is 950 W/m<sup>2</sup> for each square foot of area, determine the most economical arrangements for the available bricks.

## GIVEN

Furnace wall made of 22.5 cm × 11 cm × 7.5 cm bricks of two types

- Type 1 bricks
  - Maximum useful temperature ( $T_{1, \max}$ ) = 1040°C
  - Thermal conductivity ( $k_1$ ) = 1.7 W/(m K)
- Type 2 bricks
  - Maximum useful temperature ( $T_{2, \max}$ ) = 870°C
  - Thermal conductivity ( $k_2$ ) = 0.85 W/(m K)

Bricks cost the same

Wall hot side temperature ( $T_{\text{hot}}$ ) = 1040°C and wall cold side temperature ( $T_{\text{cold}}$ ) = 200°C

Maximum permissible heat transfer ( $q_{\max}/A$ ) = 950 W/m<sup>2</sup>

## FIND

The most economical arrangement for the bricks

## ASSUMPTIONS

One-dimensional, steady state heat transfer conditions

Constant thermal conductivities

The contact resistance between the bricks is negligible

## SKETCH

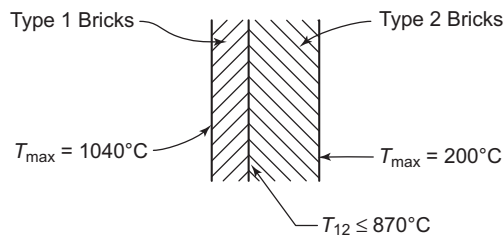

## SOLUTION

Since the type 1 bricks have a higher thermal conductivity at the same cost as the type 2 bricks, the most economical wall would use as few type 1 bricks as possible. However, there should be thick enough layer of type 1 bricks to keep the type 2 bricks at 870°C or less.

For one-dimensional conduction through type 1 bricks (from Equation 1.2)

$$q_k = \frac{k A}{L} \Delta T$$

$$\frac{q_{\max}}{A} = \frac{k_1}{L_1} (T_{\text{hot}} - T_{12})$$

where  $L_1$  is the minimum thickness of the type 1 bricks.

Solving for  $L_1$

$$L_1 = \frac{k_1}{\left(\frac{q_{\max}}{A}\right)} (T_{\text{hot}} - T_{12})$$

$$\Rightarrow L_1 = \frac{1.7 \text{ W/(m K)}}{950 \text{ W/m}^2} (1040 - 870)\text{K} = 0.3042 \text{ m} = 30.42 \text{ cm}$$

This thickness can be achieved by using 4 layers of type 1 bricks using the 7.5 cm dimension. Similarly, for one-dimensional conduction through type 2 bricks

$$L_2 = \frac{k_2}{\left(\frac{q_{\max}}{A}\right)} (T_{12} - T_{\text{cold}})$$

$$L_2 = \frac{0.85 \text{ W/(m K)}}{950 \text{ W/m}^2} (870 - 200)\text{K} = 0.6 \text{ m} = 60 \text{ cm}$$

This thickness can be achieved with 8 layers of type 2 bricks using the 7.5 cm dimension. Therefore, the most economical wall would be built using 4 layers of type 1 bricks and 8 layers of type 2 bricks with the three inch dimension of the bricks used as the thickness.

#### PROBLEM 1.4

**To measure thermal conductivity, two similar 1-cm-thick specimens are placed in an apparatus shown in the accompanying sketch. Electric current is supplied to the 6-cm by 6-cm guarded heater, and a wattmeter shows that the power dissipation is 10 watts (W). Thermocouples attached to the warmer and to the cooler surfaces show temperatures of 322 and 300 K, respectively. Calculate the thermal conductivity of the material at the mean temperature in W/(m K).**

#### GIVEN

Thermal conductivity measurement apparatus with two samples as shown

Sample thickness ( $L$ ) = 1 cm = 0.01 m

Area = 6 cm × 6 cm = 36 cm<sup>2</sup> = 0.0036 m<sup>2</sup>

Power dissipation rate of the heater ( $q_h$ ) = 10 W

Surface temperatures

- $T_{\text{hot}} = 322 \text{ K}$
- $T_{\text{cold}} = 300 \text{ K}$

#### FIND

The thermal conductivity of the sample at the mean temperature in W/(m K)

#### ASSUMPTIONS

One dimensional, steady state conduction

No heat loss from the edges of the apparatus

#### SKETCH

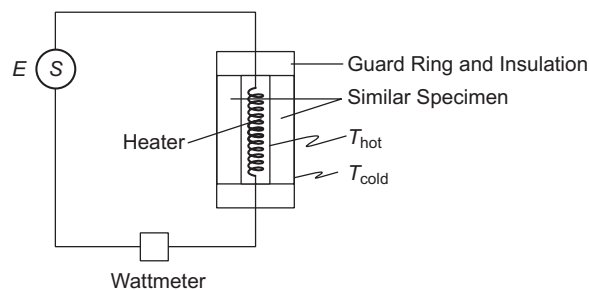

### SOLUTION

By conservation of energy, the heat loss through the two specimens must equal the power dissipation of the heater. Therefore the heat transfer through one of the specimens is  $q_h/2$ .

For one dimensional, steady state conduction (from Equation (1.3))

$$q_k = \frac{k A}{L} \Delta T = \frac{q_h}{2}$$

Solving for the thermal conductivity

$$k = \frac{q_h L}{A \Delta T}$$

$$k = \frac{(5 \text{ W})(0.01 \text{ m})}{(0.0036 \text{ m}^2)(322 \text{ K} - 300 \text{ K})}$$

$$k = 0.63 \text{ W/(mK)}$$

### COMMENTS

In the construction of the apparatus care must be taken to avoid edge losses so all the heat generated will be conducted through the two specimens.

### PROBLEM 1.5

To determine the thermal conductivity of a structural material, a large 15 cm-thick slab of the material was subjected to a uniform heat flux of  $2500 \text{ W/m}^2$ , while thermocouples embedded in the wall 2.5 cm apart were read over a period of time. After the system had reached equilibrium, an operator recorded the readings of the thermocouples as shown below for two different environmental conditions.

Distance from the surface (cm)	Temperature ( $^{\circ}\text{C}$ )
<b>Test 1:</b>	
0	40
5	65
10	97
15	132
<b>Test 2:</b>	
0	95
5	130
10	168
15	208

From these data, determine an approximate expression for the thermal conductivity as a function of temperature between  $40$  and  $208^{\circ}\text{C}$ .

### GIVEN

Thermal conductivity test on a large, 15 cm slab

Thermocouples are embedded in the wall, 2.5 cm apart

Heat flux ( $q/A$ ) =  $2500 \text{ W/m}^2$

Two equilibrium conditions were recorded (shown in Table above)

### FIND

An approximate expression for thermal conductivity as a function of temperature between 40 and 208°C.

### ASSUMPTIONS

One-dimensional conduction

### SKETCH

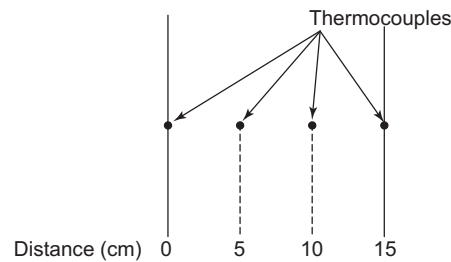

### SOLUTION

The thermal conductivity can be calculated for each pair of adjacent thermocouples using the equation for one-dimensional conduction

$$q = k A \frac{\Delta T}{L}$$

Solving for  $k$

$$k = \frac{q}{A} \frac{L}{\Delta T}$$

This will give a thermal conductivity for each pair of adjacent thermocouples which are assigned to the average temperature of the pair of thermocouples. As an example, for the first pair of thermocouples in Test 1, the thermal conductivity ( $k_o$ ) is

$$k_o = (2500 \text{ W/m}^2) \left( \frac{5 \times 10^{-2} \text{ m}}{65^\circ\text{C} - 40^\circ\text{C}} \right) = 5 \text{ W/(m K)}$$

The average temperature for this pair of thermocouples is

$$T_{\text{avg}} = \frac{40 + 65}{2} = 52.5^\circ\text{C}$$

The average temperature and the thermal conductivity for all other pairs of thermocouples are given in the table below.

$n$	(°C)	Thermal Conductivity W/(m K)
1	52.5	5
2	81	3.9
3	114.5	3.57
4	112.5	3.38
5	149	3.29
6	188	3.125

These points are displayed graphically.

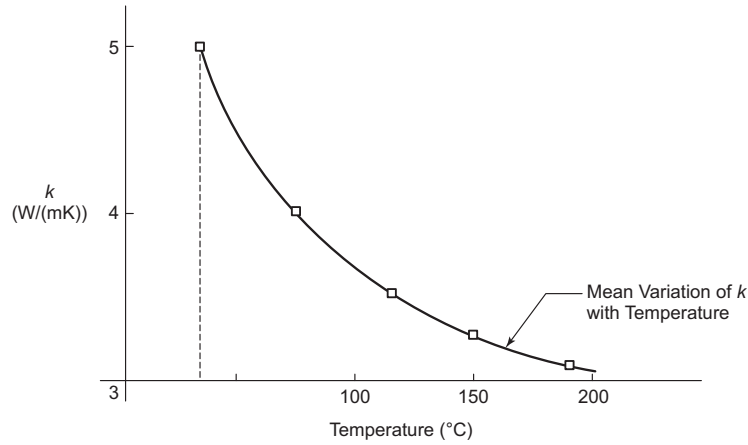

We will use the best fit quadratic function to represent the relationship between thermal conductivity and temperature

$$k(T) = a + bT + cT^2$$

The constants  $a$ ,  $b$ , and  $c$  can be found using a least squares fit.

Let the experimental thermal conductivity at data point  $n$  be designated as  $k_n$ . A least squares fit of the data can be obtained as follows

The sum of the squares of the errors is

$$S = \sum_N [k_n - k(T_n)]^2$$

$$S = \sum k_n^2 - 2a \sum k_n - Na^2 + 2ab \sum T_n - 2b \sum k_n T_n + 2ac \sum T_n^2 + b^2 \sum T_n^2 - 2c \sum k_n T_n^2 + 2bc \sum T_n^3 + c^2 \sum T_n^4$$

By setting the derivatives of  $S$  (with respect to  $a$ ,  $b$ , and  $c$ ) equal to zero, the following equations result

$$Na + \sum T_n b + \sum T_n^2 c = \sum k_n$$

$$\sum T_n a + \sum T_n^2 b + \sum T_n^3 c = \sum k_n T_n$$

$$\sum T_n^2 a + \sum T_n^3 b + \sum T_n^4 c = \sum k_n T_n^2$$

For this problem

$$\begin{aligned} \sum T_n &= 697.5 \\ \sum T_n^2 &= 9.263 \times 10^4 \\ \sum T_n^3 &= 1.3554 \times 10^7 \\ \sum T_n^4 &= 2.125 \times 10^9 \\ \sum k_n &= 22.41 \\ \sum k_n T_n &= 2445.12 \\ \sum k_n T_n^2 &= 3.124 \times 10^4 \end{aligned}$$

Solving for  $a$ ,  $b$ , and  $c$

$$\begin{aligned} a &= 6.9722 \\ b &= -4.7213 \times 10^{-2} \\ c &= 1.443 \times 10^{-4} \end{aligned}$$

Therefore the expression for thermal conductivity as a function of temperature between 40 and 208°C is

$$k(T) = 6.9722 - 4.7213 \times 10^{-2} T + 1.443 \times 10^{-4} T^2$$

This is plotted in the following graph

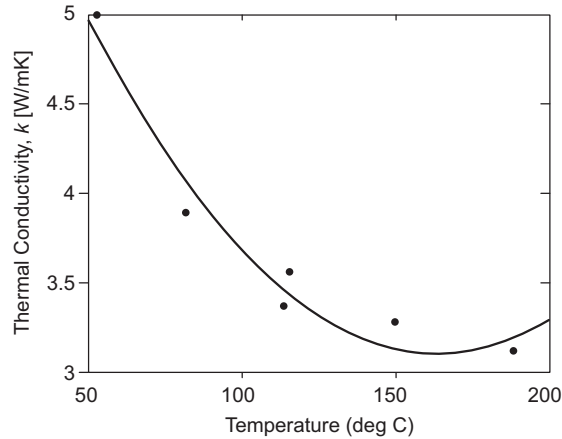

### COMMENTS

Note that the derived empirical expression is only valid within the temperature range of the experimental data.

### PROBLEM 1.6

**A square silicone chip 7 mm by 7 mm in size and 0.5 mm thick is mounted on a plastic substrate with its front surface cooled by a synthetic liquid flowing over it. Electronic circuits in the back of the chip generate heat at a rate of 5 watts that have to be transferred through the chip. Estimate the steady state temperature difference between the front and back surfaces of the chip. The thermal conductivity of silicone is 150 W/(m K).**

### GIVEN

A 0.007 m by 0.007 m silicone chip  
 Thickness of the chip ( $L$ ) = 0.5 mm = 0.0005 m  
 Heat generated at the back of the chip ( $\dot{q}_G$ ) = 5 W  
 The thermal conductivity of silicon ( $k$ ) = 150 W/(m K)

### FIND

The steady state temperature difference ( $\Delta T$ )

### ASSUMPTIONS

One dimensional conduction (edge effects are negligible)  
 The thermal conductivity is constant  
 The heat lost through the plastic substrate is negligible

### SKETCH

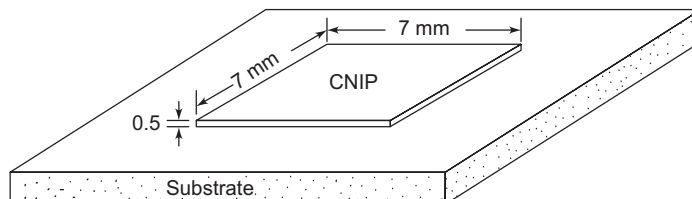



## SOLUTION

For steady state the rate of heat loss through the chip, given by Equation (1.3), must equal the rate of heat generation

$$q_k = \frac{A k}{L} (\Delta T) = \dot{q}_G$$

Solving this for the temperature difference

$$\Delta T = \frac{L \dot{q}_G}{k A}$$

$$\Delta T = \frac{(0.0005)(5 \text{ W})}{(150 \text{ W/(m K)})(0.007 \text{ m})(0.007 \text{ m})}$$

$$\Delta T = 0.34^\circ\text{C}$$

## PROBLEM 1.7

**A warehouse is to be designed for keeping perishable foods cool prior to transportation to grocery stores. The warehouse has an effective surface area of 1860 m<sup>2</sup> exposed to an ambient air temperature of 32°C. The warehouse wall insulation ( $k = 0.17 \text{ W/(m K)}$ ) is 7.5 cm thick. Determine the rate at which heat must be removed from the warehouse to maintain the food at 4°C.**

### GIVEN

Cooled warehouse

Effective area ( $A$ ) = 1860 m<sup>2</sup>

Temperatures

- Outside air = 32°C
- Food inside = 4°C

Thickness of wall insulation ( $L$ ) = 7.5 cm

Thermal conductivity of insulation ( $k$ ) = 0.17 W/(m K)

### FIND

Rate at which heat must be removed ( $q$ )

### ASSUMPTIONS

One dimensional, steady state heat flow

The food and the air inside the warehouse are at the same temperature

The thermal resistance of the wall is approximately equal to the thermal resistance of the wall insulation alone

### SKETCH

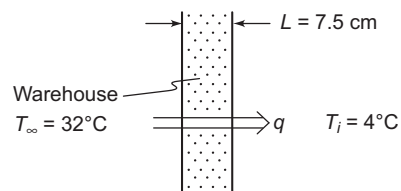

## SOLUTION

The rate at which heat must be removed is equal to the rate at which heat flows into the warehouse. There will be convective resistance to heat flow on the inside and outside of the wall. To estimate the upper limit of the rate at which heat must be removed these convective resistances will be neglected. Therefore the inside and outside wall surfaces are assumed to be at the same temperature as the air inside and outside of the wall. Then the heat flow, from Equation (1.2), is

$$q = \frac{kA}{L} \Delta T$$
$$q = \frac{(0.17 \text{ W/(m K)}) (1860 \text{ m}^2)}{7.5 \times 10^{-2} \text{ m}} (32 - 4)$$
$$q = 118 \text{ kW}$$

## PROBLEM 1.8

**With increasing emphasis on energy conservation, the heat loss from buildings has become a major concern. For a small tract house the typical exterior surface areas and R-factors (area  $\times$  thermal resistance) are listed below**

Element	Area (m <sup>2</sup> )	R-Factors = Area $\times$ Thermal Resistance [(m <sup>2</sup> K/W)]
Walls	150	2.0
Ceiling	120	2.8
Floor	120	2.0
Windows	20	0.1
Doors	5	0.5

- Calculate the rate of heat loss from the house when the interior temperature is 22°C and the exterior is -5°C.
- Suggest ways and means to reduce the heat loss and show quantitatively the effect of doubling the wall insulation and the substitution of double glazed windows (thermal resistance = 0.2 m<sup>2</sup> K/W) for the single glazed type in the table above.

## GIVEN

Small house  
Areas and thermal resistances shown in the table above  
Interior temperature = 22°C  
Exterior temperature = -5°C

## FIND

- Heat loss from the house ( $q_a$ )
- Heat loss from the house with doubled wall insulation and double glazed windows ( $q_b$ ). Suggest improvements.

## ASSUMPTIONS

All heat transfer can be treated as one dimensional  
Steady state has been reached  
The temperatures given are wall surface temperatures  
Infiltration is negligible  
The exterior temperature of the floor is the same as the rest of the house

## SOLUTION

- (a) The rate of heat transfer through each element of the house is given by Equations (1.33) and (1.34)

$$q = \frac{\Delta T}{R_{th}}$$

The total rate of heat loss from the house is simply the sum of the loss through each element:

$$q = \Delta T \left[ \frac{1}{\left(\frac{AR}{A}\right)_{wall}} + \frac{1}{\left(\frac{AR}{A}\right)_{ceiling}} + \frac{1}{\left(\frac{AR}{A}\right)_{floor}} + \frac{1}{\left(\frac{AR}{A}\right)_{windows}} + \frac{1}{\left(\frac{AR}{A}\right)_{doors}} \right]$$
$$q = (22^\circ\text{C} - -5^\circ\text{C})$$
$$\left[ \frac{1}{\left(\frac{2.0 (\text{m}^2\text{K})/\text{W}}{150 \text{ m}^2}\right)} + \frac{1}{\left(\frac{2.8 (\text{m}^2\text{K})/\text{W}}{120 \text{ m}^2}\right)} + \frac{1}{\left(\frac{2.0 (\text{m}^2\text{K})/\text{W}}{120 \text{ m}^2}\right)} + \frac{1}{\left(\frac{0.5 (\text{m}^2\text{K})/\text{W}}{20 \text{ m}^2}\right)} + \frac{1}{\left(\frac{0.5 (\text{m}^2\text{K})/\text{W}}{5 \text{ m}^2}\right)} \right]$$
$$q = (22^\circ\text{C} - -5^\circ\text{C}) (75 + 42.8 + 60 + 200 + 10) \text{ W/K}$$
$$q = 10,500 \text{ W}$$

- (b) Doubling the resistance of the walls and windows and recalculating the total heat loss:

$$q = (22^\circ\text{C} - -5^\circ\text{C})$$
$$\left[ \frac{1}{\left(\frac{4.0 (\text{m}^2\text{K})/\text{W}}{150 \text{ m}^2}\right)} + \frac{1}{\left(\frac{2.8 (\text{m}^2\text{K})/\text{W}}{120 \text{ m}^2}\right)} + \frac{1}{\left(\frac{2.0 (\text{m}^2\text{K})/\text{W}}{120 \text{ m}^2}\right)} + \frac{1}{\left(\frac{0.2 (\text{m}^2\text{K})/\text{W}}{20 \text{ m}^2}\right)} + \frac{1}{\left(\frac{0.5 (\text{m}^2\text{K})/\text{W}}{5 \text{ m}^2}\right)} \right]$$
$$q = (22^\circ\text{C} - -5^\circ\text{C}) (37.5 + 42.8 + 60 + 100 + 10) \text{ W/K}$$
$$q = 6800 \text{ W}$$

Doubling the wall and window insulation led to a 35% reduction in the total rate of heat loss.

## COMMENTS

Notice that the single glazed windows account for slightly over half of the total heat lost in case (a) and that the majority of the heat loss reduction in case (b) is due to the double glazed windows. Therefore double glazed windows are strongly suggested.

## PROBLEM 1.9

Heat is transferred at a rate of 0.1 kW through glass wool insulation (density = 100 kg/m<sup>3</sup>) of 5 cm thickness and 2 m<sup>2</sup> area. If the hot surface is at 70°C, determine the temperature of the cooler surface.

**GIVEN**

Glass wool insulation with a density ( $\rho$ ) = 100 kg/m<sup>3</sup>  
 Thickness ( $L$ ) = 5 cm = 0.05 m  
 Area ( $A$ ) = 2 m<sup>2</sup>  
 Temperature of the hot surface ( $T_h$ ) = 70°C  
 Rate of heat transfer ( $q_k$ ) = 0.1 kW = 100 W

**FIND**

The temperature of the cooler surface ( $T_c$ )

**ASSUMPTIONS**

One dimensional, steady state conduction  
 Constant thermal conductivity

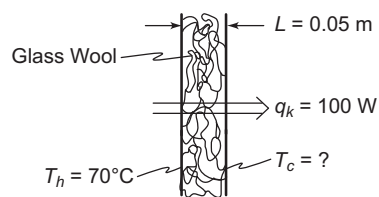
**SKETCH****PROPERTIES AND CONSTANTS**

From Appendix 2, Table 11

The thermal conductivity of glass wool at 20°C ( $k$ ) = 0.036 W/(m K)

**SOLUTION**

For one dimensional, steady state conduction, the rate of heat transfer, from Equation (1.2), is

$$q_k = \frac{A k}{L} (T_h - T_c)$$

Solving this for  $T_c$

$$T_c = T_h - \frac{q_k L}{A k}$$

$$T_c = 70^\circ\text{C} - \frac{(100 \text{ W})(0.05 \text{ m})}{(2 \text{ m}^2)(0.036 \text{ W/m K})}$$

$$T_c = 0.6^\circ\text{C}$$

**PROBLEM 1.10**

**A heat flux meter at the outer (cold) wall of a concrete building indicates that the heat loss through a wall of 10 cm thickness is 20 W/m<sup>2</sup>. If a thermocouple at the inner surface of the wall indicates a temperature of 22°C while another at the outer surface shows 6°C, calculate the thermal conductivity of the concrete and compare your result with the value in Appendix 2, Table 11.**

**GIVEN**

Concrete wall

Thickness ( $L$ ) = 100 cm = 0.1 m

Heat loss ( $q/A$ ) = 20 W/m<sup>2</sup>

Surface temperature

- Inner ( $T_i$ ) = 22°C
- Outer ( $T_o$ ) = 6°C

**FIND**

The thermal conductivity ( $k$ ) and compare it to the tabulated value

**ASSUMPTIONS**

One dimensional heat flow through the wall  
Steady state conditions exist

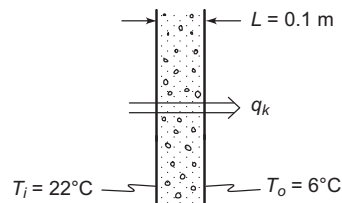
**SKETCH****SOLUTION**

The rate of heat transfer for steady state, one dimensional conduction, from Equation (1.2), is

$$q_k = \frac{k A}{L} (T_{\text{hot}} - T_{\text{cold}})$$

Solving for the thermal conductivity

$$k = \left( \frac{q_k}{A} \right) \frac{L}{(T_i - T_o)}$$

$$k = (20 \text{ W/m}^2) \left( \frac{0.1 \text{ m}^2}{22^\circ\text{C} - 6^\circ\text{C}} \right) = 0.125 \text{ W/(m K)}$$

This result is very close to the tabulated value in Appendix 2, Table 11 where the thermal conductivity of concrete is given as  $0.128 \text{ W/(m K)}$ .

**PROBLEM 1.11**

**Calculate the heat loss through a 1-m by 3-m glass window 7 mm thick if the inner surface temperature is  $20^\circ\text{C}$  and the outer surface temperature is  $17^\circ\text{C}$ . Comment on the possible effect of radiation on your answer.**

**GIVEN**

Window: 1 m by 3 m

Thickness ( $L$ ) = 7 mm = 0.007 m

Surface temperature

- Inner ( $T_i$ ) =  $20^\circ\text{C}$
- Outer ( $T_o$ ) =  $17^\circ\text{C}$

**FIND**

The rate of heat loss through the window ( $q$ )

**ASSUMPTIONS**

One dimensional, steady state conduction through the glass  
Constant thermal conductivity

## SKETCH

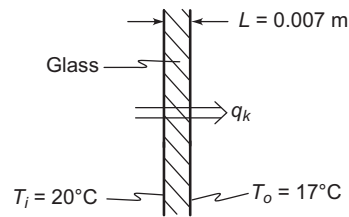

## PROPERTIES AND CONSTANTS

From Appendix 2, Table 11

Thermal conductivity of glass ( $k$ ) = 0.81 W/(m K)

## SOLUTION

The heat loss by conduction through the window is given by Equation (1.2)

$$q_k = \frac{k A}{L} (T_{\text{hot}} - T_{\text{cold}})$$
$$q_k = \frac{(0.81 \text{ W/(m K)}) (1\text{m}) (3\text{m})}{(0.007 \text{ m})} (20^\circ\text{C} - 17^\circ\text{C})$$
$$q_k = 1040 \text{ W}$$

## COMMENTS

Window glass is transparent to certain wavelengths of radiation, therefore some heat may be lost by radiation through the glass.

During the day sunlight may pass through the glass creating a net heat gain through the window.

## PROBLEM 1.12

**If in Problem 1.11 the outer air temperature is  $-2^\circ\text{C}$ , calculate the convective heat transfer coefficient between the outer surface of the window and the air assuming radiation is negligible.**

**Problem 1.11:** Calculate the heat loss through a 1 m by 3 m glass window 7 mm thick if the inner surface temperature is  $20^\circ\text{C}$  and the outer surface temperature is  $17^\circ\text{C}$ . Comment on the possible effect of radiation on your answer.

## GIVEN

Window: 1 m by 3 m

Thickness ( $L$ ) = 7 mm = 0.007 m

Surface temperatures

- Inner ( $T_i$ ) =  $20^\circ\text{C}$
- Outer ( $T_o$ ) =  $17^\circ\text{C}$

The rate of heat loss = 1040 W (from the solution to Problem 1.11)

The outside air temperature =  $-2^\circ\text{C}$

## FIND

The convective heat transfer coefficient at the outer surface of the window ( $\bar{h}_c$ )

## ASSUMPTIONS

The system is in steady state and radiative loss through the window is negligible

## SKETCH

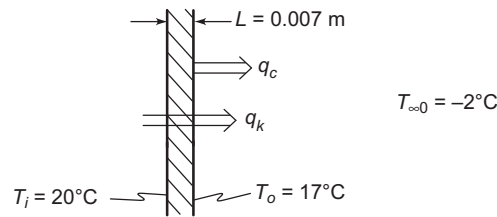

## SOLUTION

For steady state the rate of heat transfer by convection (Equation (1.10)) from the outer surface must be the same as the rate of heat transfer by conduction through the glass

$$q_c = \bar{h}_c A \Delta T = q_k$$

Solving for  $\bar{h}_c$

$$\bar{h}_c = \frac{q_k}{A(T_o - T_\infty)}$$

$$\bar{h}_c = \frac{1040 \text{ W}}{(1 \text{ m})(3 \text{ m})(17^\circ\text{C} - (-2^\circ\text{C}))}$$

$$\bar{h}_c = 18.2 \text{ W}/(\text{m}^2 \text{ K})$$

## COMMENTS

This value for the convective heat transfer coefficient falls within the range given for the free convection of air in Table 1.4.

## PROBLEM 1.13

**Using Table 1.4 as a guide, prepare a similar table showing the order of magnitudes of the thermal resistances of a unit area for convection between a surface and various fluids.**

## GIVEN

Table 1.4— The order of magnitude of convective heat transfer coefficient ( $\bar{h}_c$ )

## FIND

The order of magnitudes of the thermal resistance of a unit area ( $A R_c$ )

## SOLUTION

The thermal resistance for convection is defined by Equation (1.14) as

$$R_c = \frac{1}{\bar{h}_c A}$$

Therefore the thermal resistances of a unit area are simply the reciprocal of the convective heat transfer coefficient

$$A R_c = \frac{1}{\bar{h}_c}$$

As an example, the first item in Table 1.4 is 'air, free convection' with a convective heat transfer coefficient of 6–30 W/(m<sup>2</sup> K). Therefore the order of magnitude of the thermal resistances of a unit area for air, free convection is

$$\frac{1}{30 \text{ W/(m}^2\text{K)}} = 0.03 \text{ (m}^2\text{K)/W} \text{ to } \frac{1}{6 \text{ W/(m}^2\text{K)}} = 0.17 \text{ (m}^2\text{K)/W}$$

The rest of the table can be calculated in a similar manner

Order of Magnitude of Thermal Resistance of a Unit Area for Convection	
Fluid	W/(m <sup>2</sup> K)
Air, free convection	0.03–0.2
Superheated steam or air, forced convection	0.003–0.03
Oil, forced convection	0.0006–0.02
Water, forced convection	0.0002–0.003
Water, boiling	0.00002–0.0003
Steam, condensing	0.000008–0.0002

#### COMMENTS

The extremely low thermal resistance in boiling and condensation suggests that these resistances can often be neglected in a series thermal network.

#### PROBLEM 1.14

**A thermocouple (0.8-mm-OD wire) is used to measure the temperature of quiescent gas in a furnace. The thermocouple reading is 165°C. It is known, however, that the rate of radiant heat flow per meter length from the hotter furnace walls to the thermocouple wire is 1.1 W/m and the convective heat transfer coefficient between the wire and the gas is 6.8 W/(m<sup>2</sup> K). With this information, estimate the true gas temperature. State your assumptions and indicate the equations used.**

#### GIVEN

Thermocouple (0.8 mm OD wire) in a furnace  
 Thermocouple reading ( $T_p$ ) = 165°C  
 Radiant heat transfer to the wire ( $q_r/L$ ) = 1.1 W/m  
 Heat transfer coefficient ( $\bar{h}_c$ ) = 6.8 W/(m<sup>2</sup> K)

#### FIND

Estimate the true gas temperature ( $T_G$ )

#### ASSUMPTIONS

The system is in equilibrium  
 Conduction along the thermocouple is negligible  
 Conduction between the thermocouple and the furnace wall is negligible



## SKETCH

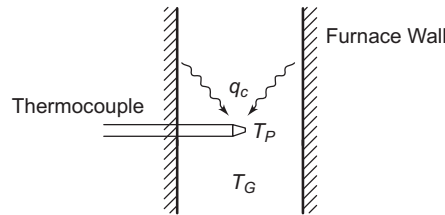

## SOLUTION

Equilibrium and the conservation of energy require that the heat gain of the probe by radiation if equal to the heat lost by convection.

The rate of heat transfer by convection is given by Equation (1.10)

$$q_c = \bar{h}_c A \Delta T = \bar{h}_c \pi D L (T_p - T_G)$$

For steady state to exist the rate of heat transfer by convection must equal the rate of heat transfer by radiation

$$q_c = q_r$$

$$\bar{h}_c \pi D L (T_p - T_G) = \left( \frac{q_r}{L} \right) L$$

$$T_G = T_p - \frac{\left( \frac{q_r}{L} \right) L}{\bar{h}_c \pi D L}$$

$$T_G = 165^\circ\text{C} - \frac{(1.1 \text{ W/m})}{(6.8 \text{ W}/(\text{m}^2\text{K})) \pi (0.0008 \text{ m})}$$

$$T_G = 101^\circ\text{C}$$

## COMMENTS

This example illustrates that care must be taken in interpreting experimental measurements. In this case a significant correction must be applied to the thermocouple reading to obtain the true gas temperature. Can you suggest ways to reduce the correction?

## PROBLEM 1.15

**Water at a temperature of  $77^\circ\text{C}$  is to be evaporated slowly in a vessel. The water is in a low pressure container which is surrounded by steam. The steam is condensing at  $107^\circ\text{C}$ . The overall heat transfer coefficient between the water and the steam is  $1100 \text{ W}/(\text{m}^2 \text{ K})$ . Calculate the surface area of the container which would be required to evaporate water at a rate of  $0.01 \text{ kg/s}$ .**

## GIVEN

Water evaporated slowly in a low pressure vessel surrounded by steam

Water temperature ( $T_w$ ) =  $77^\circ\text{C}$

Steam condensing temperature ( $T_s$ ) =  $107^\circ\text{C}$

Overall transfer coefficient between the water and the steam ( $U$ ) =  $1100 \text{ W}/(\text{m}^2 \text{ K})$

Evaporation rate ( $\dot{m}_w$ ) =  $0.01 \text{ kg/s}$

## FIND

The surface area ( $A$ ) of the container required

## ASSUMPTIONS

Steady state prevails

Vessel pressure is held constant at the saturation pressure corresponding to 77°C

## SKETCH

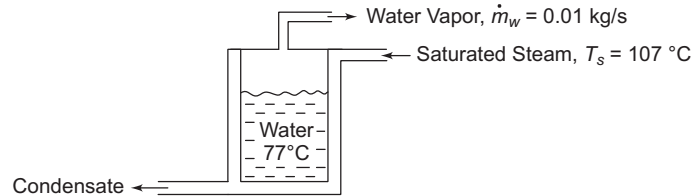

## PROPERTIES AND CONSTANTS

From Appendix 2, Table 13

The heat of vaporization of water at 77°C ( $h_{fg}$ ) = 2317 kJ/kg

## SOLUTION

The heat transfer required to evaporate water at the given rate is

$$q = \dot{m}_w h_{fg}$$

For the heat transfer between the steam and the water

$$q = U A \Delta T = \dot{m}_w h_{fg}$$

Solving this for the transfer area

$$A = \frac{\dot{m}_w h_{fg}}{U \Delta T}$$

$$A = \frac{(0.01 \text{ kg/s})(2317 \text{ kJ/kg})(1000 \text{ J/kJ})}{(1100 \text{ W/(m}^2\text{K)})(107^\circ\text{C} - 77^\circ\text{C})}$$

$$A = 0.70 \text{ m}^2$$

## PROBLEM 1.16

**The heat transfer rate from hot air at 100°C flowing over one side of a flat plate with dimensions 0.1 m by 0.5 m is determined to be 125 W when the surface of the plate is kept at 30°C. What is the average convective heat transfer coefficient between the plate and the air?**

## GIVEN

Flat plate, 0.1 m by 0.5 m, with hot air flowing over it

Temperature of plate surface ( $T_s$ ) = 30°C

Air temperature ( $T_\infty$ ) = 100°C

Rate of heat transfer ( $q$ ) = 125 W

## FIND

The average convective heat transfer coefficient,  $h_c$ , between the plate and the air

## ASSUMPTION

Steady state conditions exist

## SKETCH

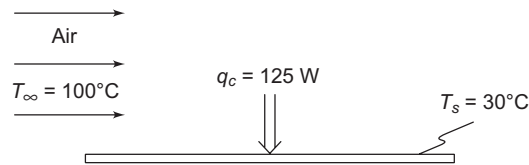

## SOLUTION

For convection the rate of heat transfer is given by Equation (1.10)

$$q_c = \bar{h}_c A \Delta T$$

$$q_c = \bar{h}_c A (T_\infty - T_s)$$

Solving this for the convective heat transfer coefficient yields

$$\bar{h}_c = \frac{q_c}{A(T_\infty - T_s)}$$

$$\bar{h}_c = \frac{125 \text{ W}}{(0.1 \text{ m})(0.5 \text{ m})(100^\circ \text{ C} - 30^\circ \text{ C})}$$

$$\bar{h}_c = 35.7 \text{ W}/(\text{m}^2 \text{ K})$$

## COMMENTS

One can see from Table 1.4 (order of magnitudes of convective heat transfer coefficients) that this result is reasonable for free convection in air.

Note that since  $T_\infty > T_s$  heat is transferred from the air to the plate.

## PROBLEM 1.17

**The heat transfer coefficient for a gas flowing over a thin flat plate 3 m long and 0.3 m wide varies with distance from the leading edge according to**

$$\bar{h}_c(x) = 10 \times \frac{1}{4} \text{ W}/(\text{m}^2 \text{ K})$$

**If the plate temperature is 170°C and the gas temperature is 30°C, calculate (a) the average heat transfer coefficient, (b) the rate of heat transfer between the plate and the gas and (c) the local heat flux 2 m from the leading edge.**

## GIVEN

Gas flowing over a 3 m long by 0.3 m wide flat plate

Heat transfer coefficient ( $h_c$ ) is given by the equation above

The plate temperature ( $T_p$ ) = 170°C

The gas temperature ( $T_G$ ) = 30°C

## FIND

- The average heat transfer coefficient ( $\bar{h}_c$ )
- The rate of heat transfer ( $q_c$ )
- The local heat flux at  $x = 2$  m ( $q_c(2)/A$ )

## ASSUMPTIONS

Steady state prevails

## SKETCH

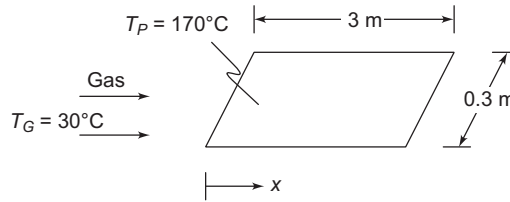

## SOLUTION

(a) The average heat transfer coefficient can be calculated by

$$\bar{h}_c = \frac{1}{L} \int_0^L h_c(x) dx = \frac{1}{L} \int_0^L 10x^{-\frac{1}{4}} dx = \frac{10}{L} \frac{4}{3} x^{\frac{3}{4}} \Big|_0^L = \frac{10}{3} \frac{4}{3} L^{\frac{3}{4}}$$
$$\bar{h}_c = 10.13 \text{ W}/(\text{m}^2 \text{ K})$$

(b) The total convective heat transfer is given by Equation (1.10)

$$q_c = \bar{h}_c A (T_P - T_G)$$
$$q_c = (10.13 \text{ W}/(\text{m}^2 \text{ K})) (3 \text{ m}) (0.3 \text{ m}) (170^\circ\text{C} - 30^\circ\text{C})$$
$$q_c = 1273 \text{ W}$$

(c) The heat flux at  $x = 2 \text{ m}$  is

$$\frac{q(x)}{A} = h_c(x) (T_P - T_G) = 10x^{-\frac{1}{4}} (T_P - T_G)$$
$$\frac{q(2)}{A} = 10(2)^{-\frac{1}{4}} (170^\circ\text{C} - 30^\circ\text{C})$$
$$\frac{q(2)}{A} = 1177 \text{ W}/\text{m}^2$$

## COMMENTS

Note that the equation for  $h_c$  does not apply near the leading edge of the plate since  $h_c$  approaches infinity as  $x$  approaches zero. This behavior is discussed in more detail in Chapter 6.

## PROBLEM 1.18

**A cryogenic fluid is stored in a 0.3 m diameter spherical container in still air. If the convective heat transfer coefficient between the outer surface of the container and the air is  $6.8 \text{ W}/(\text{m}^2 \text{ K})$ , the temperature of the air is  $27^\circ\text{C}$  and the temperature of the surface of the sphere is  $-183^\circ\text{C}$ , determine the rate of heat transfer by convection.**

## GIVEN

A sphere in still air  
Sphere diameter ( $D$ ) = 0.3 m  
Convective heat transfer coefficient  $\bar{h}_c = 6.8 \text{ W}/(\text{m}^2 \text{ K})$   
Sphere surface temperature ( $T_s$ ) =  $-183^\circ\text{C}$   
Ambient air temperature ( $T_\infty$ ) =  $27^\circ\text{C}$

**FIND**

Rate of heat transfer by convection ( $q_c$ )

**ASSUMPTIONS**

Steady state heat flow

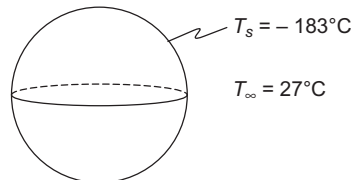
**SKETCH****SOLUTION**

The rate of heat transfer by convection is given by

$$q_c = \bar{h}_c A \Delta T$$

$$q_c = \bar{h}_c (\pi D^2) (T_\infty - T_s)$$

$$q_c = (6.8 \text{ W}/(\text{m}^2 \text{K})) \pi (0.3 \text{ m})^2 [27^\circ\text{C} - (-183^\circ\text{C})]$$

$$q_c = 404 \text{ W}$$

**COMMENTS**

Condensation would probably occur in this case due to the low surface temperature of the sphere. A calculation of the total rate of heat transfer to the sphere would have to take the rate on condensation and the rate of radiative heat transfer into account.

**PROBLEM 1.19**

**A high-speed computer is located in a temperature controlled room of  $26^\circ\text{C}$ . When the machine is operating its internal heat generation rate is estimated to be  $800 \text{ W}$ . The external surface temperature is to be maintained below  $85^\circ\text{C}$ . The heat transfer coefficient for the surface of the computer is estimated to be  $10 \text{ W}/(\text{m}^2 \text{K})$ . What surface area would be necessary to assure safe operation of this machine? Comment on ways to reduce this area.**

**GIVEN**

A high-speed computer in a temperature controlled room

Temperature of the room ( $T_\infty$ ) =  $26^\circ\text{C}$

Maximum surface temperature of the computer ( $T_c$ ) =  $85^\circ\text{C}$

Heat transfer coefficient ( $U$ ) =  $10 \text{ W}/(\text{m}^2 \text{K})$

Internal heat generation ( $\dot{q}_G$ ) =  $800 \text{ W}$

**FIND**

The surface area ( $A$ ) required and comment on ways to reduce this area

**ASSUMPTIONS**

The system is in steady state

## SKETCH

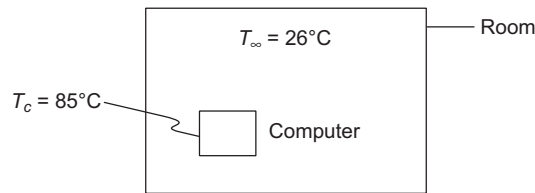

## SOLUTION

For steady state the rate of heat transfer from the computer (given by Equation (1.33)) must equal the rate of internal heat generation

$$q = U A \Delta T = \dot{q}_G$$

Solving this for the surface area

$$A = \frac{\dot{q}_G}{U \Delta T}$$

$$A = \frac{800 \text{ W}}{(10 \text{ W}/(\text{m}^2 \text{ K}))(85^\circ\text{C} - 26^\circ\text{K})} = 1.4 \text{ m}^2$$

## COMMENTS

Possibilities to reduce this surface area include

Increase the convective heat transfer from the computer by blowing air over it

Add fins to the outside of the computer

## PROBLEM 1.20

**In order to prevent frostbite to skiers on chair lifts, the weather report at most ski areas gives both an air temperature and the wind chill temperature. The air temperature is measured with a thermometer that is not affected by the wind. However, the rate of heat loss from the skier increases with wind velocity, and the wind-chill temperature is the temperature that would result in the same rate of heat loss in still air as occurs at the measured air temperature with the existing wind.**

**Suppose that the inner temperature of a 3 mm thick layer of skin with a thermal conductivity of 0.35 W/(m K) is 35°C and the ambient air temperature is -20°C. Under calm ambient conditions the heat transfer coefficient at the outer skin surface is about 20 W/(m<sup>2</sup> K) (see Table 1.4), but in a 40 mph wind it increases to 75 W/(m<sup>2</sup> K). (a) If frostbite can occur when the skin temperature drops to about 10°C, would you advise the skier to wear a face mask? (b) What is the skin temperature drop due to wind chill?**

## GIVEN

Skier's skin exposed to cold air

Skin thickness ( $L$ ) = 3 mm = 0.003 m

Inner surface temperature of skin ( $T_{si}$ ) = 35°C

Thermal conductivity of skin ( $k$ ) = 0.35 W/(m K)

Ambient air temperature ( $T_\infty$ ) = -20°C

Convective heat transfer coefficients

- Still air ( $h_{c0}$ ) = 20 W/(m<sup>2</sup> K)
- 40 mph air ( $h_{c40}$ ) = 75 W/(m<sup>2</sup> K)

Frostbite occurs at an outer skin surface temperature ( $T_{so}$ ) = 10°C

## FIND

- (a) Will frostbite occur under still or 40 mph wind conditions?
- (b) Skin temperature drop due to wind chill.

## ASSUMPTIONS

Steady state conditions prevail  
One dimensional conduction occurs through the skin  
Radiative loss (or gain from sunshine) is negligible

## SKETCH

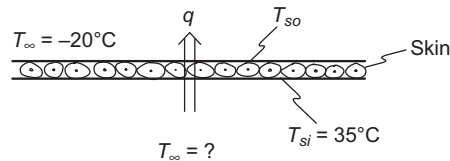

## SOLUTION

The thermal circuit for this system is shown below

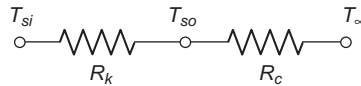

- (a) The rate of heat transfer is given by

$$q = \frac{\Delta T}{R_{\text{total}}} = \frac{\Delta T}{R_k + R_c} = \frac{T_{si} - T_{\infty}}{\left(\frac{L}{kA}\right) + \left(\frac{1}{h_c A}\right)}$$

$$\therefore \frac{q}{A} = \frac{T_{si} - T_{\infty}}{\frac{L}{k} + \frac{1}{h_c}}$$

The outer surface layer temperature of the skin in still air can be calculated by examining the conduction through the skin layer

$$q_k = \frac{kA}{L} (T_{si} - T_{so})$$

Solving for the outer skin surface temperature

$$T_{so} = T_{si} - \frac{q_k L}{A k}$$

The rate of heat transfer by conduction through the skin must be equal to the total rate of heat transfer, therefore

$$T_{so} = T_{si} - \left[ \frac{T_{si} - T_{\infty}}{\frac{L}{k} + \frac{1}{h_c}} \right] \frac{L}{k}$$

Solving this for still air

$$(T_{so})_{\text{still air}} = 35^{\circ}\text{C} - \left[ \frac{35^{\circ}\text{C} - (-20^{\circ}\text{C})}{\frac{0.003\text{m}}{0.25\text{ W/(m K)}} + \frac{1}{20\text{ W/(m}^2\text{ K)}}} \right] \frac{0.003\text{m}}{0.25\text{ W/(m}^2\text{ K)}}$$

$$(T_{so})_{\text{still air}} = 24^{\circ}\text{C}$$

For a 40 mph wind

$$(T_{so})_{40\text{ mph}} = 35^{\circ}\text{C} - \left[ \frac{35^{\circ}\text{C} - (-20^{\circ}\text{C})}{\frac{0.003\text{m}}{0.25\text{ W/(m K)}} + \frac{1}{75\text{ W/(m}^2\text{ K)}}} \right] \frac{0.003\text{m}}{0.25\text{ W/(m}^2\text{ K)}}$$

$$(T_{so})_{40\text{ mph}} = 9^{\circ}\text{C}$$

Therefore, frostbite may occur under the windy conditions.

(b) Comparing the above results we see that the skin temperature drop due to the wind chill was  $15^{\circ}\text{C}$ .

### PROBLEM 1.21

Using the information in Problem 1.20, estimate the ambient air temperature that could cause frostbite on a calm day on the ski slopes.

From Problem 1.20

Suppose that the inner temperature of a 3 mm thick layer of skin with a thermal conductivity of  $0.35\text{ W/(m K)}$  is a temperature of  $35^{\circ}\text{C}$ . Under calm ambient conditions the heat transfer coefficient at the outer skin surface is about  $20\text{ W/(m}^2\text{ K)}$ . Frostbite can occur when the skin temperature drops to about  $10^{\circ}\text{C}$ .

### GIVEN

Skier's skin exposed to cold air

Skin thickness ( $L$ ) = 3 mm = 0.003 m

Inner surface temperature of skin ( $T_{si}$ ) =  $35^{\circ}\text{C}$

Thermal conductivity of skin ( $k$ ) =  $0.35\text{ W/(m K)}$

Convective heat transfer coefficient in still air ( $\bar{h}_c$ ) =  $20\text{ W/(m}^2\text{ K)}$

Frostbite occurs at an outer skin surface temperature ( $T_{so}$ ) =  $10^{\circ}\text{C}$

### FIND

The ambient air temperature ( $T_{\infty}$ ) that could cause frostbite

### ASSUMPTIONS

Steady state conditions prevail

One dimensional conduction occurs through the skin

Radiative loss (or gain from sunshine) is negligible

### SKETCH

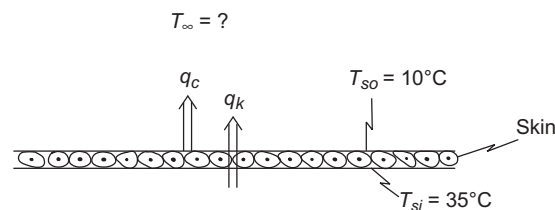



## SOLUTION

The rate of conductive heat transfer through the skin at frostbite conditions is given by Equation (1.2)

$$q_k = \frac{k A}{L} (T_{si} - T_{so})$$

The rate of convective heat transfer from the surface of the skin, from equation (1.10), is

$$q_c = \bar{h}_c A (T_{so} - T_\infty)$$

These heat transfer rates must be equal

$$q_k = q_c$$

$$\frac{k A}{L} (T_{si} - T_{so}) = \bar{h}_c A (T_{so} - T_\infty)$$

Solving for the ambient air temperature

$$T_\infty = T_{so} \left( 1 + \frac{k}{\bar{h}_c L} \right) - T_{si} \left( \frac{k}{\bar{h}_c L} \right)$$

$$T_\infty = 10^\circ\text{C} \left[ 1 + \frac{0.25 \text{ W}/(\text{m K})}{[20 \text{ W}/(\text{m}^2 \text{ K})](0.003 \text{ m})} \right] - 35^\circ\text{C}$$

$$\left[ \frac{0.25 \text{ W}/(\text{m K})}{[20 \text{ W}/(\text{m}^2 \text{ K})](0.003 \text{ m})} \right]$$

$$T_\infty = -94^\circ\text{C}$$

## PROBLEM 1.22

Two large parallel plates with surface conditions approximating those of a blackbody are maintained at 816 and 260°C, respectively. Determine the rate of heat transfer by radiation between the plates in W/m<sup>2</sup> and the radiative heat transfer coefficient in W/(m<sup>2</sup> K).

### GIVEN

Two large parallel plates, approximately black bodies

- Temperatures
- $T_1 = 816^\circ\text{C}$
  - $T_2 = 260^\circ\text{C}$

### FIND

- (a) Rate of radiative heat transfer ( $q_r/A$ ) in W/m<sup>2</sup>  
(b) Radiative heat transfer coefficient ( $h_r$ ) in W/(m<sup>2</sup> K)

### ASSUMPTIONS

Steady state prevails

Edge effects are negligible

### SKETCH

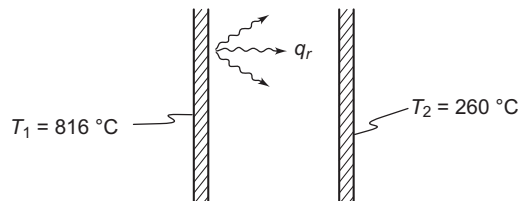

## PROPERTIES AND CONSTANTS

From Appendix 2, Table 5: Stefan-Boltzmann constant ( $\sigma$ ) =  $5.7 \times 10^{-8}$  W/(m<sup>2</sup> K<sup>4</sup>)

## SOLUTION

(a) The rate of heat transfer is given by Equation (1.16)

$$\frac{q_r}{A} = \sigma(T_1^4 - T_2^4)$$

$$\frac{q_r}{A} = (5.7 \times 10^{-8} \text{ W/(m}^2 \text{ K}^4)) [(1089 \text{ K})^4 - (533 \text{ K})^4]$$

$$\Rightarrow \frac{q_r}{A} = 75.56 \text{ (kW)/m}^2$$

(b) Let  $h_r$  represent the radiative heat transfer coefficient

$$q_r = h_r A \Delta T$$

$$\therefore h_r = \frac{q_r}{A} \frac{1}{\Delta T} = \frac{75.56 \times 10^4 \text{ W/m}^2}{(816 - 260)^\circ \text{C}}$$

$$h_r = 136 \text{ W/(m}^2 \text{ K)}$$

## COMMENTS

Note that absolute temperatures must be used in the radiative heat transfer equation, whereas  $h_r$  is based on the assumption that the rate of heat transfer is proportional to the temperature difference. Hence  $h_r$  cannot be applied to any other temperatures than those specified.

## PROBLEM 1.23

**A spherical vessel 0.3 m in diameter is located in a large room whose walls are at 27°C (see sketch). If the vessel is used to store liquid oxygen at -183°C and the surface of the storage vessel as well as the walls of the room are black, calculate the rate of heat transfer by radiation to the liquid oxygen in watts.**

## GIVEN

A black spherical vessel of liquid oxygen in a large black room

Liquid oxygen temperature ( $T_o$ ) = -183°C = 90 K

Sphere diameter ( $D$ ) = 0.3 m

Room wall temperature ( $T_w$ ) = 27°C = 300 K

## FIND

The rate of radiative heat transfer to the liquid oxygen in W

## ASSUMPTIONS

Steady state prevails

The temperature of the vessel wall is the same as the temperature of the oxygen

## SKETCH

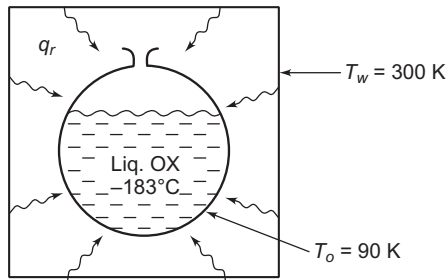

## PROPERTIES AND CONSTANTS

From Appendix 2, Table 5: The Stefan-Boltzmann constant ( $\sigma$ ) =  $5.67 \times 10^{-8} \text{ W}/(\text{m}^2 \text{ K}^4)$

## SOLUTION

The net radiative heat transfer to a black body in a black enclosure is given by Equation (1.16)

$$q_r = A \sigma (T_1^4 - T_2^4)$$
$$q_r = \pi D^2 \sigma (T_w^4 - T_o^4)$$

Converting the net radiative heat transfer into SI units using the conversion factor given on the inside front cover of the text

$$q_r = 133 \text{ W}$$

## COMMENTS

Note that absolute temperatures must be used in the radiative heat transfer equation.

## PROBLEM 1.24

**Repeat Problem 1.23 but assume that the surface of the storage vessel has an absorptance (equal to the emittance) of 0.1. Then determine the rate of evaporation of the liquid oxygen in kilograms per second and pounds per hour, assuming that convection can be neglected. The heat of vaporization of oxygen at  $-183^\circ\text{C}$  is  $213.3 \text{ kJ/kg}$ .**

**From Problem 1.23: A spherical vessel of  $0.3 \text{ m}$  in diameter is located in a large room whose walls are at  $27^\circ\text{C}$  (see sketch). If the vessel is used to store liquid oxygen at  $-183^\circ\text{C}$  and the surface of the storage vessel as well as the walls of the room are black, calculate the rate of heat transfer by radiation to the liquid oxygen in watts.**

## GIVEN

A spherical vessel of liquid oxygen in a large black room

Emittance of vessel surface ( $\epsilon$ ) = 0.1

Liquid oxygen temperature ( $T_o$ ) =  $-183^\circ\text{C} = 90 \text{ K}$

Sphere diameter ( $D$ ) =  $0.3 \text{ m}$

Room wall temperature ( $T_w$ ) =  $27^\circ\text{C} = 300 \text{ K}$

Heat of vaporization of oxygen ( $h_{fg}$ ) =  $213.3 \text{ kJ/kg}$

## FIND

- The rate of radiative heat transfer ( $q_r$ ) to the liquid oxygen in W
- The rate of evaporation of oxygen ( $m_o$ ) in kg/s and lb/h

## ASSUMPTIONS

Steady state prevails

The temperature of the vessel wall is equal to the temperature of the oxygen

Convective heat transfer is negligible

## SKETCH

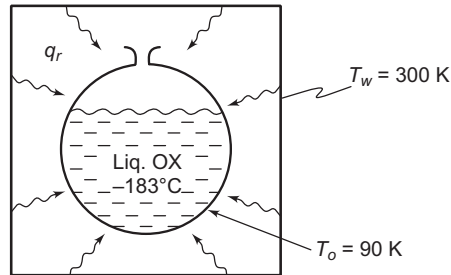

## PROPERTIES AND CONSTANTS

From Appendix 2, Table 5: The Stefan-Boltzmann constant ( $\sigma$ ) =  $5.67 \times 10^{-8}$  W/(m<sup>2</sup> K<sup>4</sup>)

## SOLUTION

(a) The net radiative heat transfer from a gray body in a black enclosure, from Equation (1.17) is

$$q_r = A_1 \varepsilon_1 \sigma (T_1^4 - T_2^4)$$

$$q_r = \pi D^2 \varepsilon \sigma (T_o^4 - T_w^4)$$

$$q_r = \pi (0.3 \text{ m})^2 (0.1) (5.67 \times 10^{-8} [\text{W}/(\text{m}^2 \text{ K}^4)] [(90 \text{ K})^4 - (300 \text{ K})^4])$$

$$q_r = -12.9 \text{ W}$$

(b) The rate of evaporation of oxygen is given by

$$\dot{m}_o = \frac{q_r}{h_{fg}}$$

$$\dot{m}_o = \frac{(12.9 \text{ W}) (\text{J}/\text{Ws})}{(213.3 \text{ kJ}/\text{kg})(1000 \text{ J}/\text{kJ})}$$

$$\dot{m}_o = 6.05 \times 10^{-5} \text{ kg/s}$$

## COMMENTS

Note that absolute temperatures must be used in the radiative heat transfer equation.

The negative sign in the rate of heat transfer indicates that the sphere is gaining heat from the surrounding wall.

Note that the rate of heat transfer by radiation can be substantially reduced (see Problem 1.23) by applying a surface treatment, e.g., applying a metallic coating with low emissivity.

## PROBLEM 1.25

**Determine the rate of radiant heat emission in watts per square meter from a blackbody at (a) 150°C, (b) 600°C, (c) 5700°C.**

## GIVEN

A blackbody

**FIND**

The rate of radiant heat emission ( $q_r$ ) in  $\text{W/m}^2$  for a temperature of

(a)  $T = 150^\circ\text{C} = 423 \text{ K}$

(b)  $T = 600^\circ\text{C} = 873 \text{ K}$

(c)  $T = 5700^\circ\text{C} = 5973 \text{ K}$

**PROPERTIES AND CONSTANTS**

From Appendix 2, Table 5: The Stefan-Boltzmann constant ( $\sigma$ ) =  $5.67 \times 10^{-8} \text{ W}/(\text{m}^2 \text{ K}^4)$

**SOLUTION**

The rate of radiant heat emission from a blackbody is given by Equation (1.15)

$$q_r = \sigma A_1 T_1^4$$

$$\frac{q_r}{A} = \sigma T^4$$

(a) For  $T = 423 \text{ K}$

$$\frac{q_r}{A} = [5.67 \times 10^{-8} \text{ W}/(\text{m}^2 \text{ K}^4)] (423 \text{ K})^4$$

$$\frac{q_r}{A} = 1820 \text{ W/m}^2$$

(b) For  $T = 873 \text{ K}$

$$\frac{q_r}{A} = [5.67 \times 10^{-8} \text{ W}/(\text{m}^2 \text{ K}^4)] (873 \text{ K})^4$$

$$\frac{q_r}{A} = 32,900 \text{ W/m}^2$$

(c) For  $T = 5973 \text{ K}$

$$\frac{q_r}{A} = [(5.67 \times 10^{-8} \text{ W}/(\text{m}^2 \text{ K}^4))] (5974 \text{ K})^4$$

$$\frac{q_r}{A} = 7.2 \times 10^7 \text{ W/m}^2$$

**COMMENTS**

Note that absolute temperatures must be used in radiative heat transfer equations.

The rate of heat transfer is proportional to the absolute temperature to the fourth power, this results in a rapid increase in the rate of heat transfer with increasing temperature.

**PROBLEM 1.26**

**The sun has a radius of  $7 \times 10^8 \text{ m}$  and approximates a blackbody with a surface temperature of about  $5800 \text{ K}$ . Calculate the total rate of radiation from the sun and the emitted radiation flux per square meter of surface area.**

**GIVEN**

The sun approximates a blackbody

Surface temperature ( $T_s$ ) =  $5800 \text{ K}$

Radius ( $r$ ) =  $7 \times 10^8 \text{ m}$

## FIND

- (a) The total rate of radiation from the sun ( $q_r$ )
- (b) The radiation flux per square meter of surface area ( $q_r/A$ )

## PROPERTIES AND CONSTANTS

From Appendix 2, Table 5: The Stefan-Boltzmann constant ( $\sigma = 5.67 \times 10^{-8} \text{ W}/(\text{m}^2 \text{ K}^4)$ )

## SOLUTION

The rate of radiation from a blackbody, from Equation (1.15), is

$$q_r = \sigma A T^4$$

$$q_r = [5.67 \times 10^{-8} \text{ W}/(\text{m}^2 \text{ K}^4)] [4\pi (7 \times 10^8 \text{ m})^2] (5800 \text{ K})^4$$

$$q_r = 4.0 \times 10^{26} \text{ W}$$

The flux per square meter is given by

$$\frac{q_r}{A} = \sigma T^4$$

$$\frac{q_r}{A} = [5.67 \times 10^{-8} \text{ W}/(\text{m}^2 \text{ K}^4)] (5800 \text{ K})^4$$

$$\frac{q_r}{A} = 6.4 \times 10^7 \text{ W}/\text{m}^2$$

## COMMENTS

The solar radiation flux impinging in the earth's atmosphere is only  $1400 \text{ W}/\text{m}^2$ . Most of the radiation from the sun goes into space.

## PROBLEM 1.27

**A small gray sphere having an emissivity of 0.5 and a surface temperature of  $537^\circ\text{C}$  is located in a blackbody enclosure having a temperature of  $37^\circ\text{C}$ . Calculate for this system: (a) the net rate of heat transfer by radiation per unit of surface area of the sphere, (b) the radiative thermal conductance in  $\text{W}/\text{K}$  if the surface area of the sphere is  $95 \text{ cm}^2$ , (c) the thermal resistance for radiation between the sphere and its surroundings, (d) the ratio of thermal resistance for radiation to thermal resistance for convection if the convective heat transfer coefficient between the sphere and its surroundings is  $11 \text{ W}/(\text{m}^2 \text{ K})$ , (e) the total rate of heat transfer from the sphere to the surroundings, and (f) the combined heat transfer coefficient for the sphere.**

## GIVEN

Small gray sphere in a blackbody enclosure

Sphere emissivity ( $\epsilon_s$ ) = 0.5

Sphere surface temperature ( $T_1$ ) =  $537^\circ\text{C} = 810 \text{ K}$

Enclosure temperature ( $T_2$ ) =  $37^\circ\text{C} = 310 \text{ K}$

The surface area of the sphere ( $A$ ) is  $95 \text{ cm}^2$

The convective transfer coefficient ( $\bar{h}_c$ ) =  $11 \text{ W}/(\text{m}^2 \text{ K})$

## FIND

- (a) Rate of heat transfer by radiation per unit surface area
- (b) Radiative thermal conductance ( $K_r$ ) in W/K
- (c) Thermal resistance for radiation ( $R_r$ )
- (d) Ratio of the radiative and conductive resistance
- (e) Total rate of heat transfer ( $q_T$ ) to the surroundings
- (f) Combined heat transfer coefficient ( $\bar{h}_{cr}$ )

## ASSUMPTIONS

Steady state prevails

The temperature of the fluid in the enclosure is equal to the enclosure temperature

## SKETCH

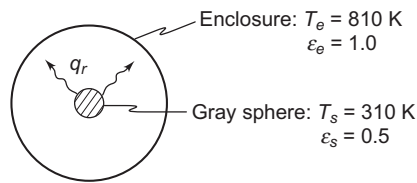

## PROPERTIES AND CONSTANTS

From Appendix 2, Table 5: The Stefan-Boltzmann constant ( $\sigma$ ) =  $5.67 \times 10^{-8} \text{ W}/(\text{m}^2 \text{ K}^4)$

## SOLUTION

- (a) For a gray body radiating to a blackbody enclosure the net heat transfer is given by Equation (1.17)

$$q_r = A_1 \epsilon_1 \sigma (T_1^4 - T_2^4)$$

$$\frac{q_r}{A} = (0.5) (5.67 \times 10^{-8} \text{ W}/(\text{m}^2 \text{ K}^4)) [(810 \text{ K})^4 - (310 \text{ K})^4]$$

$$\frac{q_r}{A} = 11.94 \text{ kW}/\text{m}^2$$

- (b) The radiative thermal conductance must be based on some reference temperature. Let the reference temperature be the enclosure temperature. Then, from Equation (1.21), the radiative thermal conductance is

$$K_r = \frac{A_1 \mathcal{F}_{1-2} \sigma (T_1^4 - T_2^4)}{T_1 - T_2} \quad \text{where } \mathcal{F}_{1-2} = \epsilon_s$$

$$K_r = \frac{(95 \times 10^{-4} \text{ m}^2)(0.5)(5.67 \times 10^{-8} \text{ W}/(\text{m}^2 \text{ K}^4))[(810 \text{ K})^4 - (310 \text{ K})^4]}{810 \text{ K} - 310 \text{ K}}$$

$$\Rightarrow K_r = 0.227 \text{ W/K}$$

- (c) The thermal resistance for radiation is given by

$$R_r = \frac{1}{K_r} = \frac{1}{0.227 \text{ (W/K)}} = 4.4 \text{ K/W}$$

- (d) The convective thermal resistance is given by Equation (1.14)

$$R_c = \frac{1}{\bar{h}_c A} = \frac{1}{(11 \text{ W}/(\text{m}^2 \text{ K}))(95 \times 10^{-4} \text{ m}^2)} = 9.57 \text{ K/W}$$

Therefore the ratio of the radiative to the convective resistance is

$$\frac{R_r}{R_c} = \frac{4.4 \text{ K/W}}{9.57 \text{ K/W}} = 0.46$$

- (e) The radiative and convective resistances are in parallel, therefore the total resistance, from Figure 1.18, is

$$R_{\text{total}} = \frac{R_c R_r}{R_c + R_r} = \frac{(9.57)(4.4)}{9.57 + 4.4} = 3.01 \text{ K/W}$$

The total heat transfer is given by

$$q_T = \frac{\Delta T}{R_{\text{total}}} = \frac{810 \text{ K} - 310 \text{ K}}{3.01 \text{ K/W}} = 166.1 \text{ W}$$

- (f) The combined heat transfer coefficient can be calculated from

$$\begin{aligned} q_T &= \bar{h}_{cr} A \Delta T \\ \therefore \bar{h}_{cr} &= \frac{q_T}{A \Delta T} = \frac{166.1 \text{ W}}{(95 \times 10^{-4} \text{ m}^2) (810 \text{ K} - 310 \text{ K})} \\ \bar{h}_{cr} &= 34.97 \text{ W}/(\text{m}^2 \text{ K}) \end{aligned}$$

## COMMENTS

Note that absolute temperatures must be used in the radiative heat transfer equations. Both heat transfer mechanisms are of the same order of magnitude in this situation.

## PROBLEM 1.28

**A spherical communications satellite 2 m in diameter is placed in orbit around the earth. The satellite generates 1000 W of internal power from a small nuclear generator. If the surface of the satellite has an emittance of 0.3 and is shaded from solar radiation by the earth, estimate the surface temperature.**

## GIVEN

Spherical satellite  
Diameter ( $D$ ) = 2 m  
Heat generation = 1000 W  
Emittance ( $\epsilon$ ) = 0.3

## FIND

The surface temperature ( $T_s$ )

## ASSUMPTIONS

The satellite radiates to space which behaves as a blackbody enclosure at 0 K  
The system is in steady state



## SKETCH

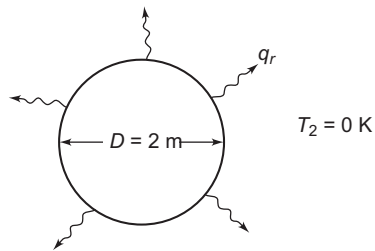

## PROPERTIES AND CONSTANTS

From Appendix 2, Table 5: The Stefan-Boltzmann constant ( $\sigma$ ) =  $5.67 \times 10^{-8} \text{ W}/(\text{m}^2 \text{ K}^4)$

## SOLUTION

From Equation (1.17), the rate of the heat transfer from a gray body in a blackbody enclosure is

$$q_r = A_1 \varepsilon_1 \sigma (T_1^4 - T_2^4)$$

Solving this for the surface temperature

$$T_1 = \left( \frac{q_r}{A_1 \varepsilon_1 \sigma} \right)^{\frac{1}{4}} = \left( \frac{q_r}{\pi D^2 \varepsilon_1 \sigma} \right)^{\frac{1}{4}}$$

For steady state the rate of heat transfer must equal the rate of internal generation, therefore the surface temperature is

$$T_1 = \left( \frac{1000 \text{ W}}{\pi (2 \text{ m})^2 (0.3) 5.67 \times 10^{-8} \text{ W}/(\text{m}^2 \text{ K}^4)} \right)^{\frac{1}{4}} = 262 \text{ K} = -11^\circ \text{C}$$

## PROBLEM 1.29

**A long wire 0.7 mm in diameter with an emissivity of 0.9 is placed in a large quiescent air space at 270 K. If the wire is at 800 K, calculate the net rate of heat loss. Discuss your assumptions.**

### GIVEN

Long wire in still air

Wire diameter ( $D$ ) = 0.7 mm

Wire temperature ( $T_s$ ) = 800 K

Emissivity ( $\varepsilon$ ) = 0.9

Air temperature ( $T_\infty$ ) = 270 K

### FIND

The net rate of heat loss

### ASSUMPTIONS

The enclosure around the wire behaves as a blackbody enclosure at the temperature of the air

The natural convection heat transfer coefficient is  $17 \text{ W}/(\text{m}^2 \text{ K})$  (From Table 1.4)

Steady state conditions prevail

## SKETCH

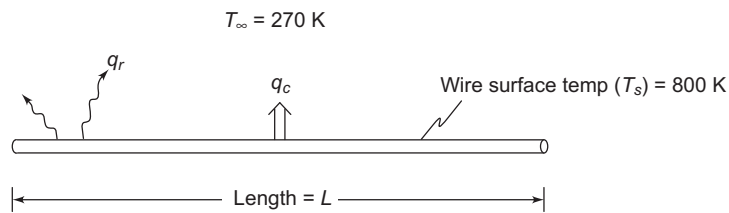

## PROPERTIES AND CONSTANTS

From Appendix 2, Table 5: The Stefan-Boltzmann constant ( $\sigma$ ) =  $5.67 \times 10^{-8} \text{ W}/(\text{m}^2 \text{ K}^4)$

## SOLUTION

The total rate of heat loss from the wire is the sum of the convective (Equation (1.10)) and radiative (Equation (1.17)) losses

$$\begin{aligned}q_{\text{total}} &= \bar{h}_c A (T_s - T_\infty) + A \varepsilon \sigma (T_s^4 - T_\infty^4) \\q_{\text{total}} &= (17 \text{ W}/(\text{m}^2 \text{ K})) \pi (0.7 \times 10^{-3}) L (800 \text{ K} - 270 \text{ K}) \\&+ \pi (0.7 \times 10^{-3}) L (0.9) (5.67 \times 10^{-8}) [(800 \text{ K})^4 - (270 \text{ K})^4] \\ \frac{q_{\text{total}}}{L} &= 65 \text{ W}/\text{m} = 65 \text{ W per m of wire length}\end{aligned}$$

## COMMENTS

The radiative heat transfer is about twice the magnitude of the convective transfer.

The enclosure is more likely a gray body, therefore the actual rate of loss will be smaller than we have calculated.

The convective heat transfer coefficient may differ by a factor of two or three from our assumed value.

## PROBLEM 1.30

**Wearing layers of clothing in cold weather is often recommended because dead-air spaces between the layers keep the body warm. The explanation for this is that the heat loss from the body is less. Compare the rate of heat loss for single 2 cm-thick layer of wool [ $k = 0.04 \text{ W}/(\text{m K})$ ] with three 0.67 cm layers separated by 1.5 mm air gaps. The thermal conductivity of air is  $0.024 \text{ W}/(\text{m K})$ .**

## GIVEN

Wool insulation

Thermal conductivities

- Wool ( $k_w$ ) =  $0.04 \text{ W}/(\text{m K})$
- Air ( $k_a$ ) =  $0.024 \text{ W}/(\text{m K})$

## FIND

Compare the rate of heat loss for a single 2 cm layer of wool to that of three 0.67 cm layers separated by 0.165 cm layers of air

## ASSUMPTIONS

Heat transfer can be approximated as one dimensional, steady state conduction

## SKETCH

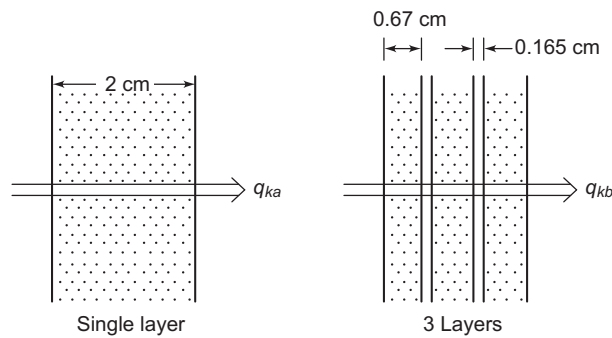

## SOLUTION

The thermal resistance for the single thick layer, from Equation (1.3), is

$$R_{ka} = \frac{L}{k_w A} = \frac{0.02 \text{ m}}{(0.04 \text{ W}/(\text{m K}))(A \text{ m}^2)} = \frac{1}{A} 0.5 \text{ K/W}$$

(A is the area of the body covered by wool)

The rate of conductive heat transfer is

$$q_{ka} = \frac{\Delta T}{R_{ka}} = \frac{\Delta T \text{ K}}{\frac{1}{A} 0.5 \text{ K/W}} = \Delta T (\text{K}) A (\text{m}^2) 2 \text{ W}$$

The thermal resistance for three thin layers equals sum of the resistances of the wool and the air between the layers

$$\begin{aligned} R_{kb} &= \frac{L_w}{k_w A} + \frac{L_a}{k_a A} \\ &= \frac{(3 \text{ layers})(0.0067 \text{ m/layer})}{A (\text{m}^2)(0.04 \text{ W}/(\text{m K}))} + \frac{(2 \text{ layers})(0.0015 \text{ m/layer})}{A (\text{m}^2)(0.024 \text{ W}/(\text{m K}))} \\ &= \frac{1}{A} [0.5 + 0.125] = \frac{1}{A (\text{m}^2)} 0.625 \text{ K/W} \end{aligned}$$

The rate of conductive heat transfer for the three layer situation is

$$q_{kb} = \frac{\Delta T}{R_{kb}} = \frac{\Delta T (\text{K})}{\frac{1}{A (\text{m}^2)} 0.625 \text{ K/W}} = \Delta T (\text{K}) A (\text{m}^2) 1.6 \text{ W}$$

Comparing the rate of heat loss for the two situations

$$\therefore \frac{q_{kb}}{q_{ka}} = \frac{1.6 \text{ W}}{2.0 \text{ W}} = 0.8$$

Therefore, for the same temperature difference, the heat loss through the three layers of wool is only 80% of the heat loss through the single layer.

**PROBLEM 1.31**

A section of a composite wall with the dimensions shown below has uniform temperatures of  $200^{\circ}\text{C}$  and  $50^{\circ}\text{C}$  over the left and right surfaces, respectively. If the thermal conductivities of the wall materials are:  $k_A = 70 \text{ W/(m K)}$ ,  $k_B = 60 \text{ W/(m K)}$ ,  $k_C = 40 \text{ W/(m K)}$  and  $k_D = 20 \text{ W/(m K)}$ , determine the rate of heat transfer through this section of the wall and the temperatures at the interfaces.

**GIVEN**

A section of a composite wall

Thermal conductivities

- $k_A = 70 \text{ W/(m K)}$
- $k_B = 60 \text{ W/(m K)}$
- $k_C = 40 \text{ W/(m K)}$
- $k_D = 20 \text{ W/(m K)}$

Surface temperatures

- Left side ( $T_{As}$ ) =  $200^{\circ}\text{C}$
- Right side ( $T_{Ds}$ ) =  $50^{\circ}\text{C}$

**FIND**

- (a) Rate of heat transfer through the wall ( $q$ )
- (b) Temperature at the interfaces

**ASSUMPTIONS**

One dimensional conduction

The system is in steady state

The contact resistances between the materials is negligible

**SKETCH**

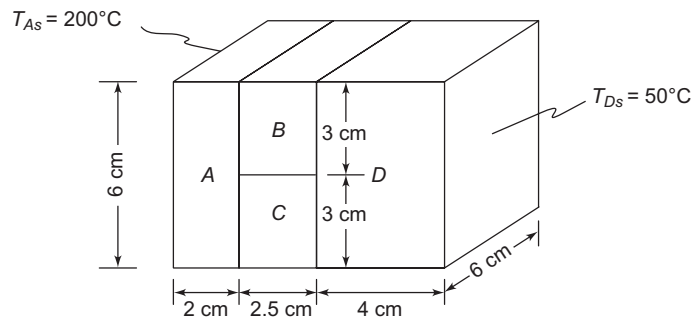

**SOLUTION**

The thermal circuit for the composite wall is shown below

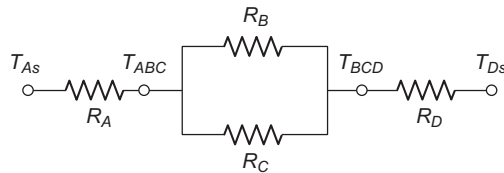

- (a) Each of these thermal resistances has a form given by Equation (1.3)

$$R_k = \frac{L}{Ak}$$

Evaluating the thermal resistance for each component of the wall

$$R_A = \frac{L_A}{A_A k_A} = \frac{0.02 \text{ m}}{(0.06 \text{ m})(0.06 \text{ m})[70 \text{ W}/(\text{m K})]} = 0.0794 \text{ K/W}$$

$$R_B = \frac{L_B}{A_B k_B} = \frac{0.025 \text{ m}}{(0.03 \text{ m})(0.06 \text{ m})[60 \text{ W}/(\text{m K})]} = 0.2315 \text{ K/W}$$

$$R_C = \frac{L_C}{A_C k_C} = \frac{0.025 \text{ m}}{(0.03 \text{ m})(0.06 \text{ m})[40 \text{ W}/(\text{m K})]} = 0.3472 \text{ K/W}$$

$$R_D = \frac{L_D}{A_D k_D} = \frac{0.04 \text{ m}}{(0.06 \text{ m})(0.06 \text{ m})[20 \text{ W}/(\text{m K})]} = 0.5556 \text{ K/W}$$

The total thermal resistance of the wall section, from Section 1.5.1, is

$$R_{\text{total}} = R_A + \frac{R_B R_C}{R_B + R_C} + R_D$$

$$R_{\text{total}} = 0.0794 + \frac{(0.2315)(0.3472)}{0.2315 + 0.3472} + 0.5556 \text{ K/W}$$

$$R_{\text{total}} = 0.7738 \text{ K/W}$$

The total rate of heat transfer through the composite wall is given by

$$q = \frac{\Delta T}{R_{\text{total}}} = \frac{200^\circ\text{C} - 50^\circ\text{C}}{0.7738 \text{ K/W}} = 194 \text{ W}$$

- (b) The average temperature at the interface between material *A* and materials *B* and *C* ( $T_{ABC}$ ) can be determined by examining the conduction through material *A* alone

$$q_{ka} = \frac{T_{As} - T_{ABC}}{R_A} = q$$

Solving for  $T_{ABC}$

$$T_{ABC} = T_{As} - q R_A = 200^\circ\text{C} - (194 \text{ W})(0.0794 \text{ K/W}) = 185^\circ\text{C}$$

The average temperature at the interface between material *D* and materials *B* and *C* ( $T_{BCD}$ ) can be determined by examining the conduction through material *D* alone

$$q_{kd} = \frac{T_{BCD} - T_{Ds}}{R_D} = q$$

Solving for  $T_{BCD}$

$$T_{BCD} = T_{Ds} + q R_D = 50^\circ\text{C} + (194 \text{ W})(0.5556 \text{ K/W}) = 158^\circ\text{C}$$

### PROBLEM 1.32

**Repeat the Problem 1.31 including a contact resistance of 0.1 K/W at each of the interfaces.**

**Problem 1.31: A section of a composite wall with the dimensions shown in the schematic diagram below has uniform temperatures of 200°C and 50°C over the left and right surfaces, respectively. If the thermal conductivities of the wall materials are:  $k_A = 70 \text{ W}/(\text{m K})$ ,  $k_B = 60 \text{ W}/(\text{m K})$ ,  $k_C = 40 \text{ W}/(\text{m K})$ , and  $k_D = 20 \text{ W}/(\text{m K})$ , determine the rate of heat transfer through this section of the wall and the temperatures at the interfaces.**

**GIVEN**

Composite wall

- Thermal conductivities
- $k_A = 70 \text{ W/(m K)}$
  - $k_B = 60 \text{ W/(m K)}$
  - $k_C = 40 \text{ W/(m K)}$
  - $k_D = 20 \text{ W/(m K)}$
  - Right side ( $T_{Ds}$ ) =  $50^\circ\text{C}$

Contact resistance at each interface ( $R_i$ ) =  $0.1 \text{ K/W}$

**FIND**

- (a) Rate of heat transfer through the wall ( $q$ )
- (b) Temperatures at the interfaces

**ASSUMPTIONS**

One dimensional conduction  
The system is in steady state

**SKETCH**

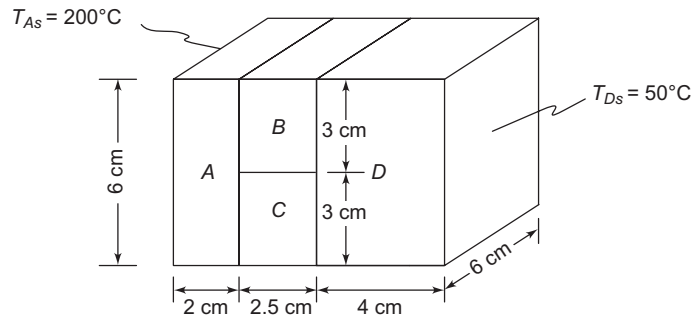

**SOLUTION**

The thermal circuit for the composite wall with contact resistances is shown below

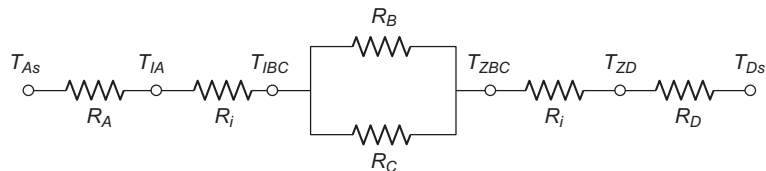

The values of the individual resistances, from Problem 1.31, are

$$R_A = 0.0794 \text{ K/W} \quad R_B = 0.2315 \text{ K/W} \quad R_C = 0.3472 \text{ K/W} \quad R_D = 0.5556 \text{ K/W}$$

- (a) The total resistance for this system is

$$R_{\text{total}} = R_A + R_i + \frac{R_B R_C}{R_B + R_C} + R_i + R_D$$

$$R_{\text{total}} = 0.0794 + 0.1 + \frac{(0.2315)(0.3472)}{0.2315 + 0.3472} + 0.1 + 0.5556 \text{ K/W}$$

$$R_{\text{total}} = 0.9738 \text{ K/W}$$

The total rate of heat transfer through the composite wall is given by

$$q = \frac{\Delta T}{R_{\text{total}}} = \frac{200^\circ\text{C} - 50^\circ\text{C}}{0.9738 \text{ K/W}} = 154 \text{ W}$$

- (b) The average temperature on the  $A$  side of the interface between material  $A$  and material  $B$  and  $C$  ( $T_{1A}$ ) can be determined by examining the conduction through material  $A$  alone

$$q = \frac{T_{As} - T_{1A}}{R_A}$$

Solving for  $T_{1A}$

$$T_{1A} = T_{As} - q R_A = 200^\circ\text{C} - (154 \text{ W}) (0.0794 \text{ K/W}) = 188^\circ\text{C}$$

The average temperature on the  $B$  and  $C$  side of the interface between material  $A$  and materials  $B$  and  $C$  ( $T_{1BC}$ ) can be determined by examining the heat transfer through the contact resistance

$$q = \frac{T_{1A} - T_{1BC}}{R_i}$$

Solving for  $T_{1BC}$

$$T_{1BC} = T_{1A} - q R_i = 188^\circ\text{C} - (154 \text{ W}) (0.1 \text{ K/W}) = 172^\circ\text{C}$$

The average temperature on the  $D$  side of the interface between material  $D$  and materials  $B$  and  $C$  ( $T_{2D}$ ) can be determined by examining the conduction through material  $D$  alone

$$q = \frac{T_{2D} - T_{Ds}}{R_D}$$

Solving for  $T_{2D}$

$$T_{2D} = T_{Ds} + q R_D = 50^\circ\text{C} + (154 \text{ W}) (0.5556 \text{ K/W}) = 136^\circ\text{C}$$

The average temperature on the  $B$  and  $C$  side of the interface between material  $D$  and materials  $B$  and  $C$  ( $T_{2BC}$ ) can be determined by examining the heat transfer through the contact resistance

$$q = \frac{T_{2BC} - T_{2D}}{R_i}$$

Solving for  $T_{2BC}$

$$T_{2BC} = T_{2D} + q R_i = 136^\circ\text{C} + (154 \text{ W}) (0.1 \text{ K/W}) = 151^\circ\text{C}$$

### COMMENTS

Note that the inclusion of the contact resistance lowers the calculated rate of heat transfer through the wall section by about 20%.

### PROBLEM 1.33

**Repeat the Problem 1.32 but assume that instead of surface temperatures, the given temperatures are those of air on the left and right sides of the wall and that the convective heat transfer coefficients on the left and right surfaces are 6 and 10 W/(m<sup>2</sup> K), respectively.**

**Problem 1.32: Repeat the Problem 1.31 including a contact resistance of 0.1 K/W at each of the interfaces.**

**Problem 1.31: A section of a composite wall with the dimensions shown in the schematic diagram below has uniform temperatures of 200°C and 50°C over the left and right surfaces, respectively. If the thermal conductivities of the wall materials are:  $k_A = 70$  W/(m K),  $k_B = 60$  W/(m K),  $k_C = 40$  W/(m K), and  $k_D = 20$  W/(m K), determine the rate of heat transfer through this section of the wall and the temperatures at the interfaces.**

## GIVEN

Composite wall

Thermal conductivities

- $k_A = 70 \text{ W/(m K)}$
- $k_B = 60 \text{ W/(m K)}$
- $k_C = 40 \text{ W/(m K)}$
- $k_D = 20 \text{ W/(m K)}$

Air temperatures

- Left side ( $T_{A\infty}$ ) =  $200^\circ\text{C}$
- Right side ( $T_{D\infty}$ ) =  $50^\circ\text{C}$

Contact resistance at each interface ( $R_i$ ) =  $0.1 \text{ K/W}$

Convective heat transfer coefficients

- Left side ( $\bar{h}_{cA}$ ) =  $6 \text{ W/(m}^2 \text{ K)}$
- Right side ( $\bar{h}_{cD}$ ) =  $10 \text{ W/(m}^2 \text{ K)}$

## FIND

- (a) Rate of heat transfer through the wall ( $q$ )
- (b) Temperatures at the interfaces

## ASSUMPTIONS

One dimensional, steady state conduction

## SKETCH

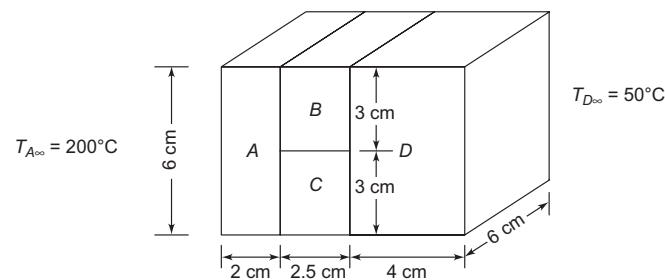

## SOLUTION

The thermal circuit for the composite wall with contact resistances and convection from the outer surfaces is shown below

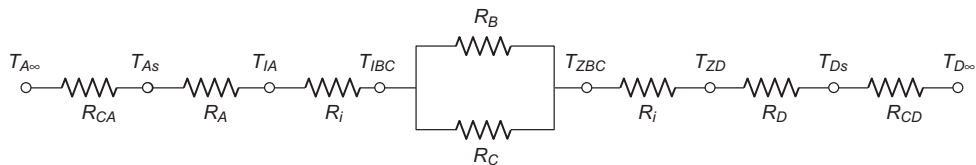

The values of the individual conductive resistances, from Problem 1.31, are

$$R_A = 0.0794 \text{ K/W} \quad R_B = 0.2315 \text{ K/W} \quad R_C = 0.3472 \text{ K/W} \quad R_D = 0.5556 \text{ K/W}$$

The values of the convective resistances, using Equation (1.14), are

$$R_{cA} = \frac{1}{\bar{h}_{cA}A} = \frac{1}{[6 \text{ W/(m}^2 \text{ K)}](0.06 \text{ m})(0.06 \text{ m})} = 46.3 \text{ K/W}$$

$$R_{cD} = \frac{1}{\bar{h}_{cD}A} = \frac{1}{[10 \text{ W/(m}^2 \text{ K)}](0.06 \text{ m})(0.06 \text{ m})} = 27.8 \text{ K/W}$$



(a) The total resistance for this system is

$$R_{\text{total}} = R_{cA} + R_A + R_i + \frac{R_B R_C}{R_B + R_C} + R_i + R_D + R_{cD}$$

$$R_{\text{total}} = 46.3 + 0.0794 + 0.1 + \frac{(0.2315)(0.3472)}{0.2315 + 0.34472} + 0.1 + 0.5556 + 27.8 \text{ K/W}$$

$$R_{\text{total}} = 75.1 \text{ K/W}$$

$$q = \frac{\Delta T}{R_{\text{total}}} = \frac{200^\circ\text{C} - 50^\circ\text{C}}{75.1 \text{ K/W}} = 2.0 \text{ W}$$

(b) The surface temperature on the left side of material A ( $T_{As}$ ) can be determined by examining the convection from the surface of material A

$$q = \frac{T_{A\infty} - T_{As}}{R_{cA}}$$

Solving for  $T_{As}$

$$T_{As} = T_{A\infty} - q R_{cA} = 200^\circ\text{C} - (2 \text{ W}) (46.3 \text{ K/W}) = 107.4^\circ\text{C}$$

The average temperature on the A side of the interface between material A and material B and C ( $T_{1A}$ ) can be determined by examining the conduction through material A alone

$$q = \frac{T_{As} - T_{1A}}{R_A}$$

Solving for  $T_{1A}$

$$T_{1A} = T_{As} - q R_A = 107.4^\circ\text{C} - (2 \text{ W}) (0.0794 \text{ K/W}) = 107.2^\circ\text{C}$$

The average temperature on the B and C side of the interface between material A and materials B and C ( $T_{1BC}$ ) can be determined by examining the heat transfer through the contact resistance

$$q = \frac{T_{1A} - T_{1BC}}{R_i}$$

Solving for  $T_{1BC}$

$$T_{1BC} = T_{1A} - q R_i = 107.2^\circ\text{C} - (2 \text{ W}) (0.1 \text{ K/W}) = 107.0^\circ\text{C}$$

The surface temperature on the D side of the wall ( $T_{Ds}$ ) can be determined by examining the convection from that side of the wall

$$q = \frac{T_{Ds} - T_{D\infty}}{R_{cD}}$$

Solving for  $T_{Ds}$

$$T_{Ds} = T_{D\infty} + q R_{cD} = 50^\circ\text{C} + (2 \text{ W}) (27.8 \text{ K/W}) = 105.6^\circ\text{C}$$

The average temperature on the D side of the interface between material D and materials B and C ( $T_{2D}$ ) can be determined by examining the conduction through material D alone

$$q = \frac{T_{2D} - T_{Ds}}{R_D}$$

Solving for  $T_{2D}$

$$T_{2D} = T_{Ds} + q R_D = 105.6^\circ\text{C} + (2 \text{ W}) (0.5556 \text{ K/W}) = 106.7^\circ\text{C}$$

The average temperature on the B and C side of the interface between material D and materials B and C ( $T_{2BC}$ ) can be determined by examining the heat transfer through the contact resistance

$$q = \frac{T_{2BC} - T_{2D}}{R_i}$$

Solving for  $T_{2BC}$

$$T_{2BC} = T_{2D} + q R_i = 106.7^\circ\text{C} + (2 \text{ W}) (0.1 \text{ K/W}) = 106.9^\circ\text{C}$$

## COMMENTS

Note that the addition of the convective resistances reduced the rate of heat transfer through the wall section by a factor of 77.

## PROBLEM 1.34

Mild steel nails were driven through a solid wood wall consisting of two layers, each 2.5 cm thick, for reinforcement. If the total cross-sectional area of the nails is 0.5% of the wall area, determine the unit thermal conductance of the composite wall and the per cent of the total heat flow that passes through the nails when the temperature difference across the wall is 25°C. Neglect contact resistance between the wood layers.

## GIVEN

Wood wall  
Two layers 0.025 m thick each  
Nail cross sectional area of nails = 0.5% of wall area  
Temperature difference ( $\Delta T$ ) = 25°C

## FIND

- The unit thermal conductance ( $k/L$ ) of the wall
- Percent of total heat flow that passes through the wall

## ASSUMPTIONS

One dimensional heat transfer through the wall  
Steady state prevails  
Contact resistance between the wall layers is negligible

## SKETCH

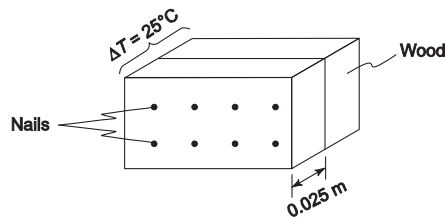

## PROPERTIES AND CONSTANTS

From Appendix 2, Tables 10 and 11

- Thermal conductivities
- Wood (Pine) ( $k_w$ ) = 0.15 W/(m K)
  - Mild steel (1% C) ( $k_s$ ) = 43 W/(m K)

## SOLUTION

- The thermal circuit for the wall is

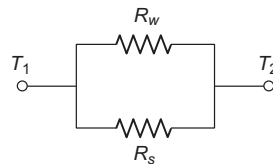

The individual resistances are

$$R_w = \frac{L_w}{A_w k_w} = \frac{0.05 \text{ m}}{(0.995 A_{\text{wall}} [0.15 \text{ W}/(\text{m K})])} = \frac{1}{A_{\text{wall}} 0.335 (\text{K m}^2)/\text{W}}$$

$$R_s = \frac{L_s}{A_s k_s} = \frac{0.05 \text{ m}}{(0.005 A_{\text{wall}} [43 \text{ W}/(\text{m K})])} = \frac{1}{A_{\text{wall}} 0.233 (\text{K m}^2)/\text{W}}$$

The total resistance of the wood and steel in parallel is

$$R_{\text{total}} = \frac{R_w R_s}{R_w + R_s} = \frac{1}{A_{\text{wall}}} \left[ \frac{(0.335)(0.233)}{0.335 + 0.233} \right] (\text{K m}^2)/\text{W} = \frac{1}{A_{\text{wall}}} 0.1374 (\text{K m}^2)/\text{W}$$

The unit thermal conductance ( $k/L$ ) is:

$$\frac{k}{L} = \frac{1}{R_{\text{total}} A_{\text{wall}}} = \frac{1}{0.1374 (\text{K m}^2)/\text{W}} = 7.3 \text{ W}/(\text{K m}^2)$$

(b) The total heat flow through the wood and nails is given by

$$q_{\text{total}} = \frac{\Delta T}{R_{\text{total}}} = \frac{25^\circ\text{C}}{\frac{1}{A_{\text{wall}}} 0.1374 (\text{K m}^2)/\text{W}}$$

$$\therefore \frac{q_{\text{total}}}{A_{\text{wall}}} = 182 \text{ W}/\text{m}^2$$

The heat flow through the nails alone is

$$q_{\text{nails}} = \frac{\Delta T}{R_{\text{nails}}} = \frac{25^\circ\text{C}}{\frac{1}{A_{\text{wall}}} 0.233 (\text{K m}^2)/\text{W}}$$

$$\therefore \frac{q_{\text{nails}}}{A_{\text{wall}}} = 107 \text{ W}/\text{m}^2$$

Therefore the percent of the total heat flow that passes through the nails is

$$\text{Percent of heat flow through nails} = \frac{107}{182} \times 100 = 59\%$$

### PROBLEM 1.35

**Calculate the rate of heat transfer through the composite wall in Problem 1.34 if the temperature difference is  $25^\circ\text{C}$  and the contact resistance between the sheets of wood is  $0.005 \text{ m}^2 \text{ K}/\text{W}$ .**

**Problem 1.34:** To reinforce a solid wall consisting of two layers, each 2.5 cm thick, mild steel nails were driven through it. If the total cross sectional area of the nails is 0.5% of the wall area, determine the unit thermal conductance of the composite wall and the percent of the total heat flow that passes through the nails when the temperature difference across the wall is  $25^\circ\text{C}$ . Neglect contact resistance between the wood layers.

### GIVEN

Wood wall           ▪ Two layers 0.025 m thick each, nailed together  
 Nail cross sectional area of nails = 0.5% of wall area  
 Temperature difference ( $\Delta T$ ) =  $20^\circ\text{C}$   
 Contact resistance ( $A R_i$ ) =  $0.005 (\text{m}^2 \text{ K})/\text{W}$

## FIND

The rate of heat transfer through the wall

## ASSUMPTIONS

One dimensional heat transfer through the wall  
Steady state prevails

## SKETCH

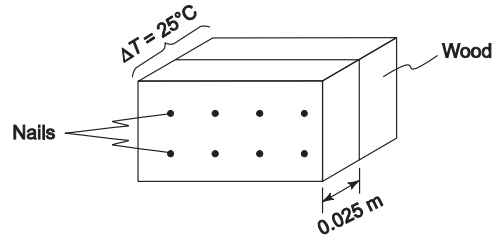

## PROPERTIES AND CONSTANTS

From Appendix 2, Tables 10 and 11

Thermal conductivities

- Wood (Pine) ( $k_w$ ) = 0.15 W/(m K)
- Mild steel (1% C) ( $k_s$ ) = 43 W/(m K)

## SOLUTION

The thermal circuit for the wall with contact resistance is shown below.

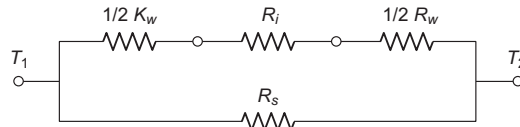

From Problem 1.34, the thermal resistance of the wood and the nails are

$$R_w = \frac{1}{A_{\text{wall}}} 0.335 \text{ (K m}^2\text{)/W} \quad R_s = \frac{1}{A_{\text{wall}}} 0.233 \text{ (K m}^2\text{)/W}$$

The combined resistance of the wood and the contact resistance in series is

$$R_{wi} = R_w + R_i = R_w + \frac{1}{A} (A R_i) = \frac{1}{A_{\text{wall}}} [0.335 \text{ (K m}^2\text{)/W} + 0.005 \text{ (K m}^2\text{)/W}]$$

$$R_{wi} = \frac{1}{A_{\text{wall}}} 0.360 \text{ (K m}^2\text{)/W}$$

The total resistance equals the combined resistance of the wood and the contact resistance in parallel with the resistance of the nails

$$R_{\text{total}} = \frac{R_{wi} R_s}{R_{wi} + R_s} = \frac{1}{A_{\text{wall}}} \left[ \frac{(0.360)(0.233)}{0.360 + 0.233} \right] \text{ (K m}^2\text{)/W} = \frac{1}{A_{\text{wall}}} = 0.1415 \text{ (K m}^2\text{)/W}$$

Therefore the rate of heat flow through the wall is:

$$q = \frac{\Delta T}{R_{\text{total}}} = \frac{25^\circ\text{C}}{\frac{1}{A_{\text{wall}}} 0.1415 \text{ (K m}^2\text{)/W}} \quad \therefore \frac{q}{A_{\text{wall}}} = 172 \text{ W/m}^2$$

## COMMENTS

In this case the inclusion of the contact resistance lowered the calculated rate of heat transfer by only 3% because most of the heat is transferred through the nails (see Problem 1.34).

## PROBLEM 1.36

Heat is transferred through a plane wall from the inside of a room at  $22^\circ\text{C}$  to the outside air at  $-2^\circ\text{C}$ . The convective heat transfer coefficients at the inside and outside surfaces are  $12$  and  $28 \text{ W}/(\text{m}^2 \text{ K})$ , respectively. The thermal resistance of a unit area of the wall is  $0.5 \text{ m}^2 \text{ K}/\text{W}$ . Determine the temperature at the outer surface of the wall and the rate of heat flow through the wall per unit area.

## GIVEN

Heat transfer through a plane wall

Air temperature

- Inside wall ( $T_i$ ) =  $22^\circ\text{C}$
- Outside wall ( $T_o$ ) =  $-2^\circ\text{C}$

Heat transfer coefficient

- Inside wall ( $\overline{h}_{ci}$ ) =  $12 \text{ W}/(\text{m}^2 \text{ K})$
- Outside wall ( $\overline{h}_{co}$ ) =  $28 \text{ W}/(\text{m}^2 \text{ K})$

Thermal resistance of a unit area ( $A R_w$ ) =  $0.5 \text{ m}^2 \text{ K}/\text{W}$

## FIND

- Temperature of the outer surface of the wall ( $T_{wo}$ )
- Rate of heat flow through the wall per unit area ( $q/A$ )

## ASSUMPTIONS

One dimensional heat flow  
Steady state has been reached

## SKETCH

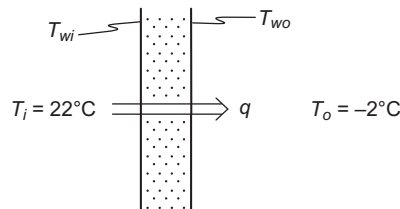

## SOLUTION

The thermal circuit for the wall is shown below

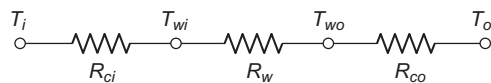

The rate of heat transfer can be used to calculate the temperature of the outer surface of the wall, therefore part (b) will be solved first.

- The heat transfer situation can be visualized using the thermal circuit shown above. The total heat transfer through the wall, from Equations (1.33) and (1.34), is

$$q = \frac{\Delta T_{\text{total}}}{R_{\text{total}}}$$

The three thermal resistances are in series, therefore

$$R_{\text{total}} = R_{ci} + R_w + R_{co}$$

$$R_{\text{total}} = \frac{1}{A h_{ci}} + \frac{A R_w}{A} + \frac{1}{A h_{\infty}}$$

The heat flow through the wall is

$$q = \frac{T_i - T_o}{\frac{1}{A} \left( \frac{1}{h_{ci}} + A R_w + \frac{1}{h_{\infty}} \right)}$$

$$\therefore \frac{q}{A} = \frac{22^\circ\text{C} - (-2^\circ\text{C})}{\frac{1}{12 \text{ W}/(\text{m}^2\text{K})} + 0.5 (\text{m}^2\text{K})/\text{W} + \frac{1}{28 \text{ W}/(\text{m}^2\text{K})}}$$

$$\frac{q}{A} = 38.8 \text{ W}/\text{m}^2$$

- (a) The temperature of the outer surface of the wall can be calculated by examining the convective heat transfer from the outside of the wall (given by Equation (1.10))

$$\frac{q_c}{A} = \bar{h}_{co} (T_{wo} - T_o)$$

Solving for  $T_{wo}$

$$T_{wo} = \frac{q}{A} \frac{1}{\bar{h}_{co}} + T_o = (38.8 \text{ W}/\text{m}^2) \left( \frac{1}{28 \text{ W}/(\text{m}^2 \text{K})} \right) + (-2^\circ\text{C}) = -0.6^\circ\text{C}$$

## COMMENTS

Note that the conductive resistance of the wall is dominant compared to the convective resistance.

## PROBLEM 1.37

**How much fiberglass insulation [ $k = 0.035 \text{ W}/(\text{m K})$ ] is needed to guarantee that the outside temperature of a kitchen oven will not exceed  $43^\circ\text{C}$ ? The maximum oven temperature to be maintained by the convective type of thermostatic control is  $290^\circ\text{C}$ , the kitchen temperature may vary from  $15^\circ\text{C}$  to  $33^\circ\text{C}$  and the average heat transfer coefficient between the oven surface and the kitchen is  $12 \text{ W}/(\text{m}^2 \text{K})$ .**

## GIVEN

Kitchen oven wall insulated with fiberglass

Fiberglass thermal conductivity ( $k$ ) =  $0.035 \text{ W}/(\text{m K})$

Convective transfer coefficient on the outside of wall ( $\bar{h}_c$ ) =  $12 \text{ W}/(\text{m}^2 \text{K})$

Maximum oven temperature ( $T_i$ ) =  $290^\circ\text{C}$

Kitchen temperature ( $T_\infty$ ) may vary:  $15^\circ\text{C} < T_\infty < 33^\circ\text{C}$

## FIND

Thickness of fiberglass ( $L$ ) to keep the temperature of the outer surface of the oven ( $T_{wo}$ ) at  $43^\circ\text{C}$  or less

## ASSUMPTIONS

One dimensional, steady state heat transfer prevails

The temperature of the inside of the wall ( $T_{wi}$ ) is the same as the oven temperature

The thermal resistance of the metal wall of the oven is negligible



## ASSUMPTIONS

One dimensional heat transfer prevails  
 The system has reached steady state  
 Radiative heat transfer is negligible

## SKETCH

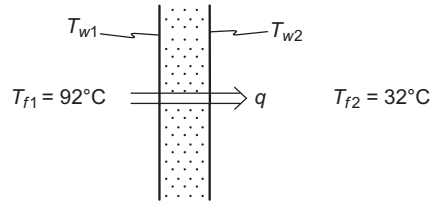

## SOLUTION

The thermal circuit for the wall is shown below

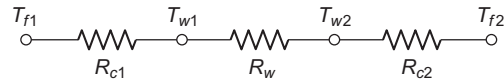

The surface temperatures can only be calculated after the heat flux has been established, therefore part (b) will be solved before part (a).

(b) The resistances are in series, therefore the total resistance is

$$R_{\text{total}} = \sum_{i=1}^3 R_i = R_{c1} + R_w + R_{c2}$$

The total rate of heat transfer is given by Equation (1.33) and (1.34)

$$q = \frac{\Delta T}{R_{\text{total}}} = \frac{\Delta T}{R_{c1} + R_w + R_{c2}} = \frac{T_1 - T_2}{\frac{1}{\bar{h}_{c1}A} + \frac{L}{kA} + \frac{1}{\bar{h}_{c2}A}}$$

Therefore the heat flux ( $q/A$ ) is

$$\Rightarrow \frac{q}{A} = \frac{92 - 32}{\frac{1}{2700 \text{ W}/(\text{m}^2\text{K})} + \frac{0.02 \text{ m}}{375 \text{ W}/(\text{m K})} + \frac{1}{7000 \text{ W}/(\text{m}^2\text{K})}} = 105.9 \text{ (kW)/m}^2$$

(a) Equation (1.10) can be applied to the convective heat transfer on the fluid 1 side

$$\frac{q_c}{A} = \bar{h}_{c1} (T_{f1} - T_{w1})$$

Solving for  $T_{w1}$

$$T_{w1} = T_{f1} - \frac{q}{A} \frac{1}{\bar{h}_{c1}} = 92^\circ\text{C} - (105.9 \text{ W}/(\text{m}^2\text{K})) \left( \frac{1}{2700 \text{ W}/(\text{m}^2\text{K})} \right) = 52.8^\circ\text{C}$$

Similarly, on the fluid 2 side

$$\frac{q_c}{A} = \bar{h}_{c2} (T_{w2} - T_{f2})$$

$$T_{w2} = T_{f2} + \frac{q}{A} \frac{1}{\bar{h}_{c2}} = 32^\circ\text{C} + (105.9 \text{ W}/(\text{m}^2\text{K})) \left( \frac{1}{7000 \text{ W}/(\text{m}^2\text{K})} \right) = 47.13^\circ\text{C}$$



### PROBLEM 1.39

A submarine is to be designed to provide a comfortable temperature for the crew of no less than  $21^{\circ}\text{C}$ . The submarine can be idealized by a cylinder 9 m in diameter and 61 m in length. The combined heat transfer coefficient on the interior is about  $14 \text{ W}/(\text{m}^2\text{K})$ , while on the outside the heat transfer coefficient is estimated to vary from about  $57 \text{ W}/(\text{m}^2\text{K})$  (not moving) to  $847 \text{ W}/(\text{m}^2\text{K})$  (top speed). For the following wall constructions, determine the minimum size in kilowatts of the heating unit required if the sea water temperatures vary from  $1.1$  to  $12.8^{\circ}\text{C}$  during operation. The walls of the submarine are (a) 2 cm aluminium (b) 1.8 cm stainless steel with a 2.5 cm thick layer fiberglass insulation on the inside and (c) of sandwich construction with a 1.8 cm thickness of stainless steel, a 2.5 cm thick layer of fiberglass insulation, and a 0.6 cm thickness of aluminium on the inside. What conclusions can you draw?

### GIVEN

- Submarine
- Inside temperature ( $T_i$ )  $> 21^{\circ}\text{C}$
- Can be idealized as a cylinder
- Diameter ( $D$ ) = 9 m
  - length ( $L$ ) = 61 m
- Combined heat transfer coefficients
- Inside ( $\bar{h}_{ci}$ ) =  $14 \text{ W}/(\text{m}^2\text{K})$
  - Outside ( $\bar{h}_{co}$ ): not moving =  $57 \text{ W}/(\text{m}^2\text{K})$   
: top speed:  $847 \text{ W}/(\text{m}^2\text{K})$

Sea water temperature ( $T_o$ ) varies:  $1.1^{\circ}\text{C} < T_o < 12.8^{\circ}\text{C}$

### FIND

Minimum size of the heating unit ( $q$ ) in kW for

- 1.2 cm thick aluminium walls
- 1.8 cm thick stainless steel with 2.5 cm of fiberglass insulation
- Sandwich of 1.8 cm stainless steel, 2.5 cm of fiberglass insulation, and 0.6 cm of aluminium

### ASSUMPTIONS

Steady state prevails

Heat transfer can be approximated as heat transfer through a flat plate with the surface area of the cylinder

Constant thermal conductivities

Contact resistance between the difference materials is negligible

### SKETCH

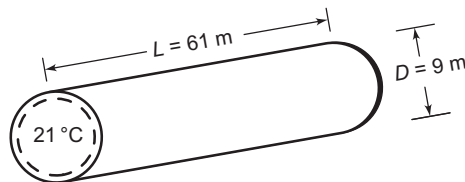

### PROPERTIES AND CONSTANTS

From Appendix 2, Tables 10, 11, and 12: The thermal conductivities are

Aluminium ( $k_a$ ) =  $236 \text{ W}/(\text{m K})$  at  $0^{\circ}\text{C}$

Stainless steel ( $k_s$ ) =  $14 \text{ W}/(\text{m K})$  at  $20^{\circ}\text{C}$

Fiberglass insulation ( $k_{fg}$ ) =  $0.035 \text{ W}/(\text{m K})$  at  $20^{\circ}\text{C}$

## SOLUTION

The thermal circuits for the three cases are shown below

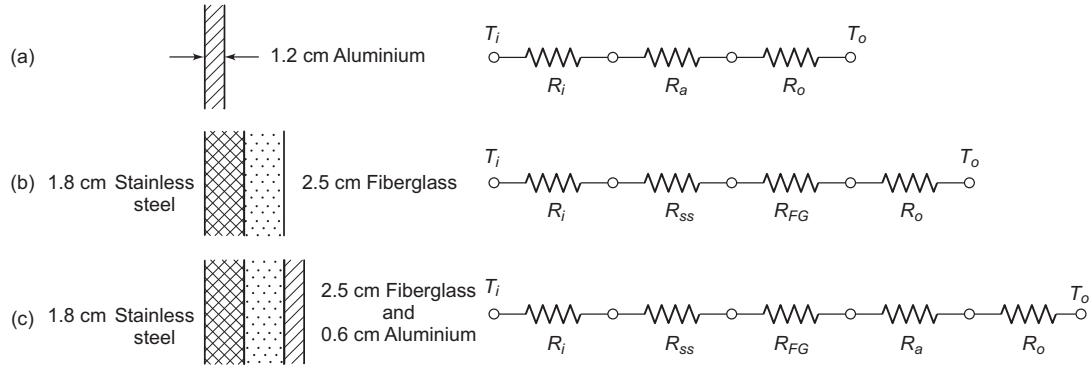

The total surface area of the idealized submarine ( $A$ ) is

$$A = \pi DL + 2\pi \frac{D^2}{4} = (61 \text{ m})\pi(9 \text{ m}) + \frac{\pi}{2} (9 \text{ m})^2 = 1850 \text{ m}^2$$

(a) For case (a) the total resistance is

$$R_{\text{total}} = \sum_{i=1}^3 R_i = R_i + R_a + R_o = \frac{1}{\bar{h}_{ci}A} + \frac{L}{k_a A} + \frac{1}{\bar{h}_{co}A}$$

The heat transfer through the wall is

$$q = \frac{\Delta T}{R_{\text{total}}} = \frac{T_i - T_o}{\frac{1}{\bar{h}_{ci}A} + \frac{L_a}{k_a A} + \frac{1}{\bar{h}_{co}A}}$$

By examination of the above equation, the heater requirement will be the largest when  $T_o$  is at its minimum value and  $\bar{h}_{co}$  is at its maximum value

$$\Rightarrow q = \frac{(1850 \text{ m}^2)(21 - 1.1)\text{K}}{\frac{1}{14 \text{ W}/(\text{m}^2\text{K})} + \frac{1.2 \times 10^{-2} \text{ m}}{(236 \text{ W}/(\text{m K}))} + \frac{1}{847 \text{ W}/(\text{m}^2\text{K})}}$$

$$q = 507 \text{ kW}$$

(b) Similarly, for case (b), the total resistance is

$$R_{\text{total}} = \sum_{i=1}^4 R_i = R_s + R_a + R_{fg} + R_o = \frac{1}{\bar{h}_{ci}A} + \frac{L_s}{k_s A} + \frac{L_{fg}}{k_{fg} A} + \frac{1}{\bar{h}_{co}A}$$

The size of heater needed is

$$q = \frac{(1850 \text{ m}^2)(21 - 1.1)\text{K}}{\frac{1}{14 \text{ W}/(\text{m}^2\text{K})} + \frac{1.8 \times 10^{-2} \text{ m}}{14 \text{ W}/(\text{m K})} + \frac{2.5 \times 10^{-2} \text{ m}}{0.035 \text{ W}/(\text{m K})} + \frac{1}{847 \text{ W}/(\text{m}^2\text{K})}}$$

$$\Rightarrow q = 46.7 \text{ kW}$$

(c) The total resistance for case (c) is

$$R_{\text{total}} = \sum_{i=1}^5 R_i = R_s + R_a + R_{fg} + R_a + R_o = \frac{1}{h_{ci}A} + \frac{L_s}{k_sA} + \frac{L_{fg}}{k_{fg}A} + \frac{L_a}{k_aA} + \frac{1}{h_{co}A}$$

The size of heater needed is

$$q = \frac{(1850\text{m}^2)(21-1.1)\text{K}}{\frac{1}{14\text{ W}/(\text{m}^2\text{K})} + \frac{1.8 \times 10^{-2}\text{ m}}{14\text{ W}/(\text{mK})} + \frac{2.5 \times 10^{-2}\text{ m}}{0.035\text{ W}/(\text{mK})} + \frac{0.6 \times 10^{-2}}{236\text{ W}/(\text{mK})} + \frac{1}{847\text{ W}/(\text{m}^2\text{K})}}$$

$$\Rightarrow q = 46.7\text{ kW}$$

### COMMENTS

Neither the aluminium nor the stainless steel offers any appreciable resistance to heat loss.

Fiberglass or other low conductivity material is necessary to keep the heat loss down to a reasonable level.

### PROBLEM 1.40

**A simple solar heater consists of a flat plate of glass below which is located a shallow pan filled with water, so that the water is in contact with the glass plate above it. Solar radiation is passing through the glass at the rate of  $490\text{ W}/\text{m}^2$ . The water is at  $92^\circ\text{C}$  and the surrounding air is  $27^\circ\text{C}$ . If the heat transfer coefficients between the water and the glass and the glass and the air are  $28\text{ W}/(\text{m}^2\text{K})$ , and  $7\text{ W}/(\text{m}^2\text{K})$ , respectively, determine the time required to transfer  $1.1\text{ MJ}/\text{m}^2$  of surface to the water in the pan. The lower surface of the pan may be assumed to be insulated.**

### GIVEN

A simple solar heater: shallow pan of water below glass, the water touches the glass

Solar radiation passing through glass ( $q_r/A$ ) =  $490\text{ W}/\text{m}^2$

Water temperature ( $T_w$ ) =  $92^\circ\text{C}$

Surrounding air temperature ( $T_\infty$ ) =  $27^\circ\text{C}$

- Heat transfer coefficients
- Between water and glass ( $\bar{h}_{cw}$ ) =  $28\text{ W}/(\text{m}^2\text{K})$
  - Between glass and air ( $\bar{h}_{ca}$ ) =  $7\text{ W}/(\text{m}^2\text{K})$

### FIND

The time ( $t$ ) required to transfer  $11\text{ (kJ)}/\text{m}^2$  to the water

### ASSUMPTIONS

One dimensional, steady state heat transfer prevails

The heat loss from the bottom of the pan is negligible

The radiative loss from the top of the glass is negligible

The thermal resistance of the glass is negligible

### SKETCH

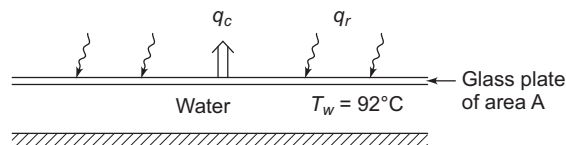

## SOLUTION

The total thermal resistance between the water and the surrounding air is the sum of the two convective thermal resistances

$$R_{\text{total}} = \sum_{i=1}^2 R_i = R_{cw} + R_{ca} = \frac{1}{h_{cw}A} + \frac{1}{h_{ca}A}$$
$$R_{\text{total}} = \frac{1}{A(28 \text{ W}/(\text{m}^2\text{K}))} + \frac{1}{A(7 \text{ W}/(\text{m}^2\text{K}))} = \frac{1}{A(\text{m}^2)} 0.178 (\text{m}^2\text{K})/\text{W}$$

The net rate of heat transfer to the water is

$$\frac{q_{\text{total}}}{A} = \frac{q_r}{A} = \frac{q_c}{A} = \frac{q_r}{A} = \frac{\Delta T}{A R_{\text{total}}}$$
$$\frac{q_{\text{total}}}{A} = 490 \text{ W}/\text{m}^2 - \frac{92^\circ\text{C} - 27^\circ\text{C}}{A \left( \frac{1}{A} 0.178 (\text{K m}^2)/\text{W} \right)}$$
$$\frac{q_{\text{Total}}}{A} = 125 \text{ W}/\text{m}^2$$

At this rate, the time required to transfer 1.1 MJ to the water per  $\text{m}^2$  area is

$$t = \frac{\text{total energy incident per unit area}}{\text{heat flux}}$$
$$= \frac{1.1 \times 10^6 \text{ J}/\text{m}^2}{125 \text{ W}/\text{m}^2} = 2.45 \text{ hours}$$
$$\Rightarrow t = 2.45 \text{ hours}$$

## PROBLEM 1.41

A composite refrigerator wall is composed of 5 cm of corkboard sandwiched between a 1.2 cm thick layer of oak and a 0.8 mm thickness of aluminium lining on the inner surface. The average convective heat transfer coefficients at the interior and exterior wall are 11 and 8.5  $\text{W}/(\text{m}^2\text{K})$ , respectively. (a) Draw the thermal circuit. (b) Calculate the individual resistances of the components of this composite wall and the resistances at the surfaces. (c) Calculate the overall heat transfer coefficient through the wall. (d) For an air temperature inside the refrigerator of  $-1^\circ\text{C}$  and outside of  $32^\circ\text{C}$ , calculate the rate of heat transfer per unit area through the wall.

### GIVEN

Refrigerator wall: oak, corkboard, and aluminium

Thicknesses

- Oak ( $L_o$ ) = 1.2 cm
- Corkboard ( $L_c$ ) = 5 cm
- Aluminum ( $L_a$ ) = 0.8 mm

Convective heat transfer coefficients

- Interior ( $\bar{h}_{ci}$ ) = 11  $\text{W}/(\text{m}^2\text{K})$
- Exterior ( $\bar{h}_{co}$ ) = 8.5  $\text{W}/(\text{m}^2\text{K})$

Air temperature

- Inside ( $T_i$ ) =  $-1^\circ\text{C}$ ;
- Outside ( $T_o$ ) =  $32^\circ\text{C}$

**FIND**

- (a) Draw the thermal circuit
- (b) The individual resistances
- (c) Overall heat transfer coefficient ( $U$ )
- (d) Rate of heat transfer per unit area ( $q/A$ )

**ASSUMPTIONS**

One dimensional, steady state heat transfer  
 Constant thermal conductivities  
 Contact resistance between the different materials is negligible

**SKETCH**

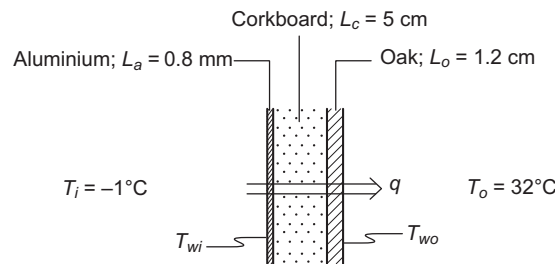

**PROPERTIES AND CONSTANTS**

From Appendix 2, Tables 11 and 12, the thermal conductivities are

- Oak ( $k_o$ ) = 0.2 W/(m K) at 20°C
- Corkboard ( $k_c$ ) = 0.04 W/(m K) at 20°C
- Aluminium ( $k_a$ ) = 235 W/(m K) at 0°C

**SOLUTION**

(a) The thermal circuit for the refrigerator wall is shown below

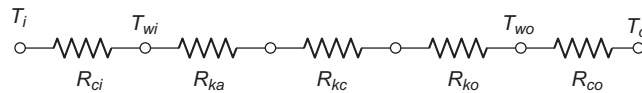

(b) The resistance to convection from the inner and outer surfaces is given by Equation (1.14)

$$R_c = \frac{1}{h_c A}$$

This means

$$R_{ci} = \frac{1}{h_{ci} A} = \frac{1}{(11 \text{ W}/(\text{m}^2 \text{ K}))A(\text{m}^2)} = \frac{1}{A(\text{m}^2)} 0.091 (\text{K m}^2)/\text{W}$$

$$R_{co} = \frac{1}{h_{co} A} = \frac{1}{(8.5 \text{ W}/(\text{m}^2 \text{ K}))A(\text{m}^2)} = \frac{1}{A(\text{m}^2)} 0.117 (\text{K m}^2)/\text{W}$$

The resistance to conduction through the components of the wall is given by Equation (1.3)

$$R_k = \frac{L}{A k}$$

That is

$$R_{ka} = \frac{L_a}{A k_a} = \frac{(0.8 \times 10^{-3} \text{ m})}{A(\text{m}^2)(235 \text{ W}/(\text{m K}))} = \frac{1}{A(\text{m}^2)} 3.4 \times 10^{-6} (\text{K m}^2)/\text{W}$$

$$R_{kc} = \frac{L_c}{Ak_c} = \frac{5 \times 10^{-2} \text{ m}}{A(\text{m}^2)(0.04 \text{ W}/(\text{m K}))} = \frac{1}{A(\text{m}^2)} 1.25 \text{ (K m}^2\text{)}/\text{W}$$

$$R_{ko} = \frac{L_o}{Ak_o} = \frac{1.2 \times 10^{-2} \text{ m}}{A(\text{m}^2)(0.2 \text{ W}/(\text{m K}))} = \frac{1}{A(\text{m}^2)} 0.06 \text{ (K m}^2\text{)}/\text{W}$$

(c) The overall heat transfer coefficient satisfies Equation (1.34)

$$UA = \frac{1}{R_{\text{total}}}$$

$$\therefore U = \frac{1}{AR_{\text{total}}} = \frac{1}{A(R_{ci} + R_{ka} + R_{kc} + R_{ko} + R_{co})}$$

$$\Rightarrow U = \frac{1}{(0.091 + 3.4 \times 10^{-6} + 1.25 + 0.06 + 0.117) \text{ (K m}^2\text{)}/\text{W}}$$

$$\Rightarrow U = 0.66 \text{ W}/(\text{m}^2\text{K})$$

(d) The rate of heat transfer through the wall is given by Equation (1.33)

$$\frac{q}{A} = U \Delta T = (0.66 \text{ W}/(\text{m}^2\text{K})) (32 + 1) \text{ K} = 21.8 \text{ W}/\text{m}^2$$

## COMMENTS

The thermal resistance of the corkboard is more than three times greater than the sum of the other resistances. The thermal resistance of the aluminum is negligible.

## PROBLEM 1.42

**An electronic device that internally generates 600 mW of heat has a maximum permissible operating temperature of 70°C. It is to be cooled in 25°C air by attaching aluminum fins with a total surface area of 12 cm<sup>2</sup>. The convective heat transfer coefficient between the fins and the air is 20 W/(m<sup>2</sup> K). Estimate the operating temperature when the fins are attached in such a way that: (a) there exists a contact resistance between the surface of the device and the fin array of approximately 50 K/W, and (b) there is no contact resistance but the construction of the device is more expensive. Comment on the design options.**

## GIVEN

An electronic device with aluminum fin array

Device generates heat at a rate ( $\dot{q}_G$ ) = 600 mW = 0.6 W

Surface area ( $A$ ) = 12 cm<sup>2</sup>

Max temperature of device = 70°C

Air temperature ( $T_\infty$ ) = 25°C

Convective heat transfer coefficient ( $\bar{h}_c$ ) = 20 W/(m<sup>2</sup> K)

## FIND

Operating temperature ( $T_o$ ) for

(a) contact resistance ( $R_i$ ) = 50 K/W

(b) no contact resistance

## ASSUMPTIONS

One dimensional heat transfer

Steady state has been reached

The temperature of the device is uniform  
 The temperature of the aluminum fins is uniform (the thermal resistance of the aluminum is negligible)  
 The heat loss from the edges and back of the device is negligible

**SKETCH**

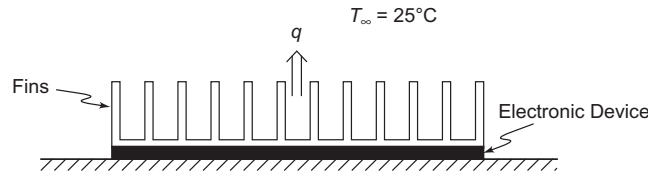

**SOLUTION**

(a) The thermal circuit for the case with contact resistance is shown below

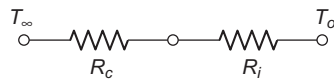

The value of the convective resistance, from Equation (1.14), is

$$R_c = \frac{1}{h_c A} = \frac{1}{[20 \text{ W}/(\text{m}^2 \text{ K})](0.0012 \text{ m}^2)} = 41.7 \text{ K/W}$$

For steady state conditions, the heat loss from the device ( $q$ ) must be equal to the heat generated by the device

$$q = \frac{\Delta T}{R_{\text{total}}} = \frac{T_o - T_\infty}{R_c + R_i} = \dot{q}_G$$

Solving for  $T_o$

$$T_o = T_\infty + \dot{q}_G (R_c + R_i) = 25^\circ\text{C} + (0.6 \text{ W}) (41.7 \text{ K/W} + 50 \text{ K/W}) = 80^\circ\text{C}$$

(b) Similarly, the operating temperature of the device with no contact resistance is

$$T_o = T_\infty + \dot{q}_G R_c = 25^\circ\text{C} + (0.6 \text{ W}) (41.7 \text{ K/W}) = 50^\circ\text{C}$$

**COMMENTS**

The more expensive device with no contact resistance will have to be used to assure that the operating temperature does not exceed  $70^\circ\text{C}$ .

**PROBLEM 1.43**

To reduce the home heating requirements, modern building codes in many parts of the country require the use of double-glazed or double-pane windows, i.e., windows with two panes of glass. Some of these so called thermopane windows have an evacuated space between the two glass panes while others trap stagnant air in the space.

(a) Consider a double-pane window with the dimensions shown in the following sketch. If this window has stagnant air trapped between the two panes and the convective heat transfer coefficients on the inside and outside surfaces are  $4 \text{ W}/(\text{m}^2 \text{ K})$  and  $15 \text{ W}/(\text{m}^2 \text{ K})$ , respectively, calculate the overall heat transfer coefficient for the system.

(b) If the inside air temperature is  $22^\circ\text{C}$  and the outside air temperature is  $-5^\circ\text{C}$ , compare the heat loss through a  $4 \text{ m}^2$  double-pane window with the heat loss through a single-pane window. Comment on the effect of the window frame on this result.

(c) The total window area of a home heated by electric resistance heaters at a cost of  $\$.10/\text{kWh}$  is  $80 \text{ m}^2$ . How much more cost can you justify for the double-pane windows if the average temperature difference during the six winter months when heating is required is about  $15^\circ\text{C}$ ?

## GIVEN

Double-pane window with stagnant air in gap

Convective heat transfer coefficients

- Inside ( $\bar{h}_{ci}$ ) = 4 W/(m<sup>2</sup> K)
- Outside ( $\bar{h}_{co}$ ) = 15 W/(m<sup>2</sup> K)

Air temperatures

- Inside ( $T_i$ ) = 22°C
- Outside ( $T_o$ ) = -5°C

Single window area ( $A_w$ ) = 4 m<sup>2</sup>

During the winter months, ( $\Delta T$ ) = 15°C

Heating cost = \$.1.0/kWh

Total window area ( $A_T$ ) = 80 m<sup>2</sup>

## FIND

- The overall heat transfer coefficient
- Compare heat loss of double- and single-pane window

## ASSUMPTIONS

Steady state conditions prevail

Radiative heat transfer is negligible

## SKETCH

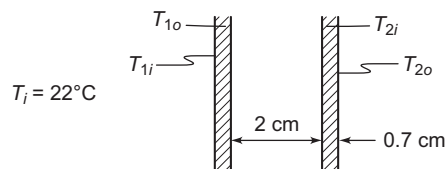

## PROPERTIES AND CONSTANTS

From Appendix 2, Tables 11 and 27, the thermal conductivities are  
window glass ( $k_g$ ) = 0.81 W/(m K) at 20°C; dry air ( $k_a$ ) = 0.0243 W/(m K) at 8.5°C

## SOLUTION

The thermal circuit for the system is shown below

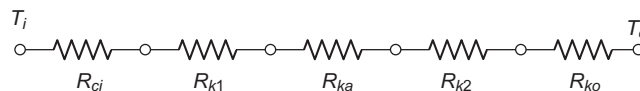

The individual resistances are

$$R_{co} = \frac{1}{\bar{h}_{co} A} = \frac{1}{[15 \text{ W}/(\text{m}^2 \text{ K})] A} = \frac{1}{A} 0.0667 \text{ (K m}^2\text{)/W}$$

$$R_{k1} = R_{k2} = \frac{L_g}{A k_g} = \frac{0.007 \text{ m}}{A [0.81 \text{ W}/(\text{m K})]} = \frac{1}{A} 0.00864 \text{ (K m}^2\text{)/W}$$

$$R_{ka} = \frac{L_a}{A k_a} = \frac{0.02 \text{ m}}{A [0.0243 \text{ W}/(\text{m K})]} = \frac{1}{A} 0.823 \text{ (K m}^2\text{)/W}$$

$$R_{ci} = \frac{1}{\bar{h}_{ci} A} = \frac{1}{[4 \text{ W}/(\text{m}^2 \text{ K})] A} = \frac{1}{A} 0.25 \text{ (K m}^2\text{)/W}$$



The total resistance for the double-pane window is

$$R_{\text{total}} = \sum_{i=1}^5 R_i = R_{co} + R_{k1} + R_{ka} + R_{k2} + R_{ci}$$

$$R_{\text{total}} = \frac{1}{A} (0.0667 + 0.00864 + 0.823 + 0.00864 + 0.25) (\text{m}^2 \text{ K})/\text{W} = \frac{1}{A} 1.157 (\text{K m}^2)/\text{W}$$

Therefore the overall heat transfer coefficient is

$$U_{\text{double}} = \frac{1}{A R_{\text{total}}} = \frac{1}{1.157 (\text{m}^2 \text{ K})/\text{W}} = 0.864 \text{ W}/(\text{m}^2 \text{ K})$$

(b) The rate of heat loss through the double-pane window is

$$q_{\text{double}} = U A \Delta T = [0.864 \text{ W}/(\text{m}^2 \text{ K})] (4 \text{ m}^2) [22^\circ\text{C} - (-5^\circ\text{C})] = 93 \text{ W}$$

The thermal circuit for the single-pane window is

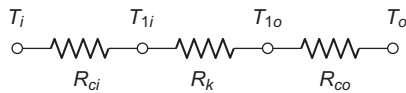

The total thermal resistance for the single-pane window is

$$R_{\text{total}} = \sum_{i=1}^3 R_i = R_{co} + R_{k1} + R_{ci} = \frac{1}{A} (0.0667 + 0.00864 + 0.25) (\text{m}^2 \text{ K})/\text{W}$$

$$R_{\text{total}} = 0.325 (\text{m}^2 \text{ K})/\text{W}$$

The overall heat transfer coefficient for the single-pane window is

$$U_{\text{single}} = \frac{1}{A R_{\text{total}}} = \frac{1}{0.325 (\text{m}^2 \text{ K})/\text{W}} = 3.08 \text{ W}/(\text{m}^2 \text{ K})$$

Therefore, the rate of heat loss through the single-pane window is

$$q_{\text{single}} = U A \Delta T = [3.07 \text{ W}/(\text{m}^2 \text{ K})] (4 \text{ m}^2) [22^\circ\text{C} - (-5^\circ\text{C})] = 332 \text{ W}$$

The heat loss through the double-pane window is only 28% of that through the single-pane window.

(c) The average heat loss through double-pane windows during the winter months is

$$q_{\text{double}} = U A_T \Delta T = [0.864 \text{ W}/(\text{m}^2 \text{ K})] (80 \text{ m}^2) 15^\circ\text{C} = 1040 \text{ W}$$

Therefore, the cost of the heat loss from the double-pane windows is

$$\text{Cost}_{\text{double}} = q_{\text{double}} (\text{heating cost})$$

$$\text{Cost}_{\text{double}} = (1040 \text{ W}) (\$0.10/\text{kWh}) (24 \text{ h/day}) (182 \text{ heating days/year}) (1 \text{ kW}/1000 \text{ W})$$

$$\text{Cost}_{\text{double}} = \$454/\text{yr}$$

The average heat loss through the single-pane windows during the winter months is

$$q_{\text{single}} = U A_T \Delta T = [3.07 \text{ W}/(\text{m}^2 \text{ K})] (80 \text{ m}^2) (15^\circ\text{C}) = 3688 \text{ W}$$

The cost of this heat loss is

$$\text{Cost}_{\text{single}} = q_{\text{single}} (\text{heat cost})$$

$$\text{Cost}_{\text{single}} = (3688 \text{ W}) (\$0.10/\text{kWh}) (24 \text{ h/day}) (182 \text{ heating days/year}) (1 \text{ kW}/1000 \text{ W})$$

$$\text{Cost}_{\text{single}} = \$1611/\text{yr}$$

The yearly savings of the double-pane windows is \$1157. Therefore if we would like to have a payback period of two years, we would be willing to invest \$2314 in double panes.

### PROBLEM 1.44

A flat roof can be modeled as a flat plate insulated on the bottom and placed in the sunlight. If the radiant heat that the roof receives from the sun is  $600 \text{ W/m}^2$ , the convection heat transfer coefficient between the roof and the air is  $12 \text{ W/(m}^2 \text{ K)}$ , and the air temperature is  $27^\circ\text{C}$ , determine the roof temperature for the following two cases: (a) Radiative heat loss to space is negligible. (b) The roof is black ( $\varepsilon = 1.0$ ) and radiates to space, which is assumed to be a black-body at  $0 \text{ K}$ .

#### GIVEN

A flat plate in the sunlight

Radiant heat received from the sun ( $q_r/A$ ) =  $600 \text{ W/m}^2$

Air temperature ( $T_\infty$ ) =  $27^\circ\text{C}$

Convective heat transfer coefficient ( $\bar{h}_c$ ) =  $12 \text{ W/(m}^2 \text{ K)}$

#### FIND

The plate temperature ( $T_p$ )

#### ASSUMPTIONS

Steady state prevails

No heat is lost from the bottom of the plate

#### SKETCH

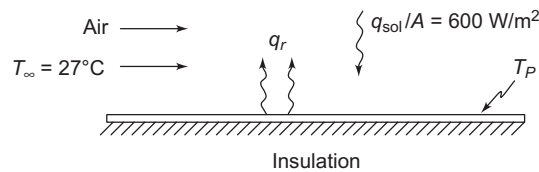

#### PROPERTIES AND CONSTANTS

From Appendix 1, Table 5: Stefan-Boltzmann constant ( $\sigma$ ) =  $5.67 \times 10^{-8} \text{ W/(m}^2 \text{ K}^4)$

#### SOLUTION

- (a) For this case steady state and the conservation of energy require the heat lost by conduction, from Equation (1.10), to be equal to the heat gained from the sun

$$q_c = \bar{h}_c A (T_s - T_\infty) = q_r$$

Solving for  $T_s$

$$T_s = \frac{q_r}{A} \frac{1}{\bar{h}_c} + T_\infty = (600 \text{ W/m}^2) \left( \frac{1}{12 \text{ W/(m}^2 \text{ K)}} \right) + (27^\circ\text{C}) = 77^\circ\text{C}$$

- (b) In this case, the solar gain must be equal to the sum of the convective loss, from Equation (1.10), and radiative loss, from Equation (1.16)

$$\frac{q_r}{A} = \bar{h}_c (T_p - T_\infty) + \sigma (T_p^4 - T_{sp}^4)$$

$$600 \text{ W/m}^2 = 12 \text{ W/(m}^2 \text{ K)} (T_p - 300\text{K}) + 5.67 \times 10^{-8} \text{ W/(m}^2 \text{ K}^4) (T_p^4 - 0)$$

By trial and error

$$T_p = 308 \text{ K} = 35^\circ\text{C}$$

## COMMENTS

The addition of a second means of heat transfer from the plate in part (b) allows the plate to operate at a significantly lower temperature.

## PROBLEM 1.45

**A horizontal 3-mm-thick flat copper plate, 1 m long and 0.5 m wide, is exposed in air at 27°C to radiation from the sun. If the total rate of solar radiation absorbed is 300 W and the combined radiative and convective heat transfer coefficients on the upper and lower surfaces are 20 and 15 W/(m<sup>2</sup> K), respectively, determine the equilibrium temperature of the plate.**

## GIVEN

Horizontal, 1 m long, 0.5 m wide, and 3 mm thick copper plate is exposed to air and solar radiation

Air temperature ( $T_\infty$ ) = 27°C

Solar radiation absorbed ( $q_{sol}$ ) = 300 W

Combined transfer coefficients are

- Upper surface ( $\bar{h}_u$ ) = 20 W/(m<sup>2</sup> K)
- Lower surface ( $\bar{h}_l$ ) = 15 W/(m<sup>2</sup> K)

## FIND

The equilibrium temperature of the plate ( $T_p$ )

## ASSUMPTIONS

Steady state prevails

The temperature of the plate is uniform

## SKETCH

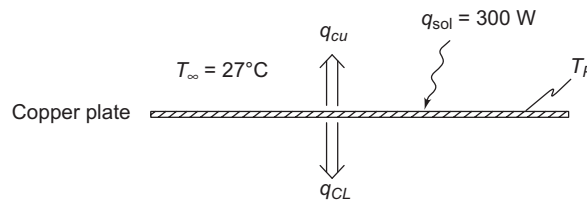

## SOLUTION

For equilibrium the heat gain from the solar radiation must equal the heat lost from the upper and lower surfaces

$$q_{sol} = \bar{h}_u A (T_p - T_\infty) + \bar{h}_l A (T_p - T_\infty)$$

Solving for  $T_p$

$$T_p = \frac{q_{sol}}{A} \frac{1}{\bar{h}_u + \bar{h}_l} + T_\infty$$

$$T_p = \left( \frac{300 \text{ W}}{(1 \text{ m})(0.5 \text{ m})} \right) \left( \frac{1}{20 \text{ W}/(\text{m}^2 \text{ K}) + 15 \text{ W}/(\text{m}^2 \text{ K})} \right) + (27^\circ \text{C})$$

$$T_p = 44^\circ \text{C}$$

### PROBLEM 1.46

A small oven with a surface area of  $0.28 \text{ m}^2$  is located in a room in which the walls and the air are at a temperature of  $27^\circ\text{C}$ . The exterior surface of the oven is at  $150^\circ\text{C}$  and the net heat transfer by radiation between the oven's surface and the surroundings is  $586 \text{ W}$ . If the average convective heat transfer coefficient between the oven and the surrounding air is  $11 \text{ W}/(\text{m}^2\text{K})$ , calculate: (a) the net heat transfer between the oven and the surroundings in  $\text{W}$ , (b) the thermal resistance at the surface for radiation and convection, respectively, in  $\text{K}/\text{W}$ , and (c) the combined heat transfer coefficient in  $\text{W}/(\text{m}^2\text{K})$ .

### GIVEN

Small oven in a room

Oven surface area ( $A$ ) =  $0.28 \text{ m}^2$

Room wall and air temperature ( $T_\infty$ ) =  $27^\circ\text{C}$

Surface temperature of the exterior of the oven ( $T_o$ ) =  $150^\circ\text{C}$

Net radiative heat transfer ( $q_r$ ) =  $586 \text{ W}$

Convective heat transfer coefficient ( $\bar{h}_c$ ) =  $11 \text{ W}/(\text{m}^2\text{K})$

### FIND

- (a) Net heat transfer ( $q_T$ ) in  $\text{W}$
- (b) Thermal resistance for radiation and convection ( $R_T$ ) in  $\text{K}/\text{W}$
- (c) The combined heat transfer coefficient ( $\bar{h}_{cr}$ ) in  $\text{W}/(\text{m}^2\text{K})$

### ASSUMPTIONS

Steady state prevails

### SKETCH

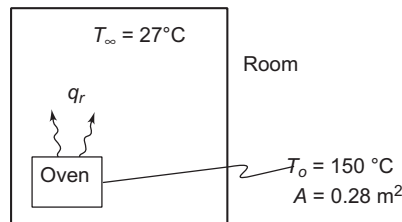

### SOLUTION

- (a) The net heat transfer is the sum of the convective heat transfer, from Equation (1.10), and the net radiative heat transfer

$$q_T = q_c + q_r + \bar{h}_c A (T_o - T_\infty) + q_r$$

This gives

$$\begin{aligned} q_T &= 11 \text{ W}/(\text{m}^2\text{K}) (0.28 \text{ m}^2) (150 - 27)\text{K} + 586 \text{ W} = 965 \text{ W} \\ &= 379 \text{ W} + 586 \text{ W} \end{aligned}$$

- (b) The radiative resistance is

$$R_r = \frac{T_o - T_\infty}{q_r} = \frac{(150 - 27)\text{K}}{586 \text{ W}} = 0.21 \text{ K}/\text{W}$$

The convective resistance is

$$R_c = \frac{T_o - T_\infty}{q_c} = \frac{(150 - 27)\text{K}}{379\text{ W}} = 0.325\text{ K/W}$$

These two resistances are in parallel, therefore the total resistance is given by

$$R_T = \frac{R_c R_r}{R_c + R_r} = \left( \frac{(0.21\text{ K/W})(0.325\text{ K/W})}{(0.21 + 0.325)\text{ K/W}} \right) = 0.13\text{ K/W}$$

(c) The combined heat transfer coefficient can be calculated from

$$q_T = \bar{h}_{cr} A \Delta T$$

$$\therefore \bar{h}_{cr} = \frac{q_r}{A \Delta T} = \frac{965\text{ W}}{(0.28\text{ m}^2)(150 - 27)\text{ K}} = 28\text{ W}/(\text{m}^2\text{ K})$$

### COMMENTS

The thermal resistances for the convection and radiation modes are of the same order of magnitude. Hence, neglecting either one would lead to a considerable error in the rate of heat transfer.

### PROBLEM 1.47

**A steam pipe 200 mm in diameter passes through a large basement room. The temperature of the pipe wall is 500°C, while that of the ambient air in the room is 20°C. Determine the heat transfer rate by convection and radiation per unit length of steam pipe if the emissivity of the pipe surface is 0.8 and the natural convection heat transfer coefficient has been determined to be 10 W/(m<sup>2</sup> K).**

### GIVEN

A steam pipe passing through a large basement room  
 Pipe diameter ( $\Delta$ ) = 200 mm = 0.2 m  
 The temperature of the pipe wall ( $T_p$ ) = 500°C = 773 K  
 Temperature of ambient air in the room ( $T_\infty$ ) = 20°C = 293 K  
 Emissivity of the pipe surface ( $\varepsilon$ ) = 0.8  
 Natural convection heat transfer coefficient ( $h_c$ ) = 10 W/(m<sup>2</sup> K)

### FIND

Heat transfer rate by convection and radiation per unit length of the steam pipe ( $q/L$ )

### ASSUMPTIONS

Steady state prevails  
 The walls of the room are at the same temperature as the air in the room  
 The walls of the room are black ( $\varepsilon = 1.0$ )

### SKETCH

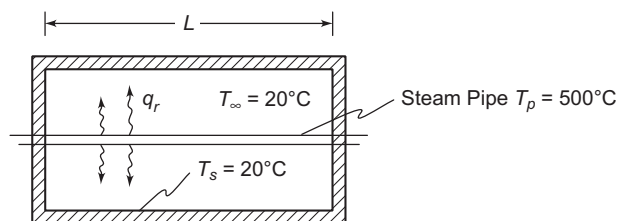

## PROPERTIES AND CONSTANTS

From Appendix 1, Table 5, the Stefan-Boltzmann constant ( $\sigma$ ) =  $5.67 \times 10^{-8} \text{ W}/(\text{m}^2 \text{ K}^4)$

## SOLUTION

The net radiative heat transfer rate for a gray object in a blackbody enclosure is given by Equation (1.17)

$$q_r = A_1 \varepsilon_1 \sigma (T_1^4 - T_2^4) = \pi D L \varepsilon \sigma (T_p^4 - T_s^4)$$
$$\therefore \frac{q_r}{L} = \pi (0.2 \text{ m}) (0.8) [5.67 \times 10^{-8} \text{ W}/(\text{m}^2 \text{ K}^4)] [(773 \text{ K})^4 - (293 \text{ K})^4]$$
$$\frac{q_r}{L} = 9970 \text{ W/m}$$

The convective heat transfer rate is given by

$$q_c = \bar{h}_c A (T_p - T_\infty) = \bar{h}_c (\pi D L) (T_p - T_\infty)$$
$$\therefore \frac{q_c}{L} = [10 \text{ W}/(\text{m}^2 \text{ K})] \pi (0.2 \text{ m}) (500^\circ\text{C} - 20^\circ\text{C})$$
$$\frac{q_c}{L} = 3020 \text{ W/m}$$

## COMMENTS

Note that absolute temperatures must be used in the radiative heat transfer equation.

The radiation heat transfer dominates because of the high emissivity of the surface and the high surface temperature which enters to the fourth power in the rate of radiative heat loss.

## PROBLEM 1.48

**The inner wall of a rocket motor combustion chamber receives  $160(\text{kW})/\text{m}^2$  by radiation from a gas at  $2760^\circ\text{C}$ . The convective heat transfer coefficient between the gas and the wall is  $110 \text{ W}/(\text{m}^2\text{K})$ . If the inner wall of the combustion chamber is at a temperature of  $540^\circ\text{C}$ , determine the total thermal resistance of a unit area of the wall in  $(\text{m}^2\text{K})/\text{W}$  and the heat flux. Also draw the thermal circuit.**

## GIVEN

Wall of a rocket motor combustion chamber  
Radiation to inner surface ( $q_r/A$ ) =  $160 \text{ (kW)}/\text{m}^2$   
Temperature of gas in chamber ( $T_g$ ) =  $2760^\circ\text{C}$   
Convective heat transfer coefficient on inner wall ( $h_c$ ) =  $110 \text{ W}/(\text{m}^2\text{K})$   
Temperature of inner wall ( $T_w$ ) =  $540^\circ\text{C}$

## FIND

- Draw the thermal circuit
- The total thermal resistance of a unit area ( $A R_{\text{total}}$ ) in  $(\text{m}^2\text{K})/\text{W}$

## ASSUMPTIONS

One dimensional heat transfer through the walls of the combustion chamber  
Steady state heat flow

**SKETCH**

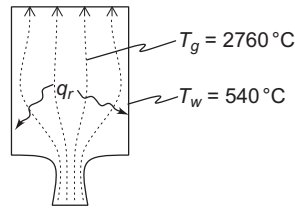

**SOLUTION**

(a) The thermal circuit for the chamber wall is shown below

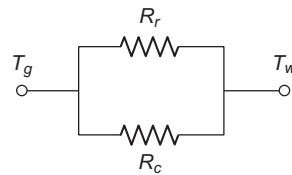

(b) The total thermal resistance can be calculated from the total rate of heat transfer from the pipe

$$q_{\text{total}} = \frac{\Delta T}{R_{\text{total}}}$$

$$\therefore A R_{\text{total}} = \frac{\Delta T}{\left(\frac{q_{\text{total}}}{A}\right)}$$

The total rate of heat transfer is the sum of the radiative and convective heat transfer

$$q_{\text{total}} = q_r + q_c = q_r + \bar{h}_c A \Delta T$$

$$\therefore \frac{q_{\text{total}}}{A} = \frac{q_r}{A} + \bar{h}_c \Delta T$$

$$\frac{q_{\text{total}}}{A} = 160000 \text{ W/m}^2 + 110 \text{ W/(m}^2\text{K)} (2760 - 540)\text{K} = 404,200 \text{ W/m}^2$$

Therefore the thermal resistance of a unit area is

$$A R_{\text{total}} = \frac{(2760 - 540)\text{K}}{404,200 \text{ W/m}^2} = 0.0055 \text{ (m}^2\text{K)/W}$$

-----

An alternate method of solving part (b) is to calculate the radiative and convective resistances separately and then combine them in parallel as illustrated below.

The convective resistance is

$$R_c = \frac{1}{\bar{h}_c A} = \frac{1}{A} \left( \frac{1}{110 \text{ W/(m}^2\text{K)}} \right) = \frac{1}{A} 0.0091 \text{ (m}^2\text{K)/W}$$

The radiative resistance is

$$R_r = \frac{\Delta T}{q_r} = \frac{\Delta T}{A \left(\frac{q_r}{A}\right)} = \frac{1}{A} \frac{(2760 - 540)\text{K}}{160000 \text{ W/m}^2} = \frac{1}{A} 0.014 \text{ (m}^2\text{K)/W}$$

Combining these two resistances in parallel yields the total resistance

$$R_{\text{total}} = \frac{R_r R_c}{R_r + R_c}$$

$$\therefore A R_{\text{total}} = \frac{(0.0091)(0.014)}{(0.0091 + 0.014)} (\text{m}^2 \text{K})/\text{W} = 0.0055 (\text{m}^2 \text{K})/\text{W}$$

#### PROBLEM 1.49

A flat roof of a house absorbs a solar radiation flux of  $600 \text{ W/m}^2$ . The backside of the roof is well insulated, while the outside loses heat by radiation and convection to ambient air at  $20^\circ\text{C}$ . If the emittance of the roof is  $0.80$  and the convective heat transfer coefficient between the roof and the air is  $12 \text{ W/(m}^2 \text{ K)}$ , calculate: (a) the equilibrium surface temperature of the roof, and (b) the ratio of convective to radiative heat loss. Can one or the other of these be neglected? Explain your answer.

#### GIVEN

Flat roof of a house

Solar flux absorbed ( $q_{\text{sol}}/A$ ) =  $600 \text{ W/m}^2$

Back of roof is well insulated

Ambient air temperature ( $T_\infty$ ) =  $20^\circ\text{C} = 293 \text{ K}$

Emittance of the roof ( $\epsilon$ ) =  $0.80$

Convective heat transfer coefficient ( $\bar{h}_c$ ) =  $12 \text{ W/(m}^2 \text{ K)}$

#### FIND

- The equilibrium surface temperature ( $T_s$ )
- The ratio of the convective to radiative heat loss

#### ASSUMPTIONS

The heat transfer from the back surface of the roof is negligible

Steady state heat flow

#### SKETCH

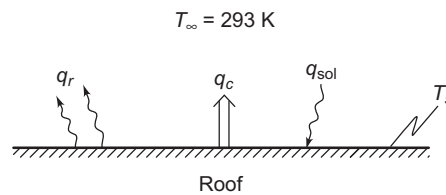

#### PROPERTIES AND CONSTANTS

From Appendix 1, Table 5, the Stefan-Boltzmann constant ( $\sigma$ ) =  $5.67 \times 10^{-8} \text{ W/(m}^2 \text{ K}^4)$

#### SOLUTION

- For steady state the sum of the convective heat loss, from Equation (1.10), and the radiative heat loss, from Equation (1.15), must equal the solar gain

$$\frac{q_{\text{sol}}}{A} = \frac{q_c}{A} + \frac{q_r}{A} = \bar{h}_c (T_s - T_\infty) + \epsilon \sigma T_s^4$$

$$600 \text{ W/m}^2 = 12 \text{ W/(m}^2 \text{ K)} (T_s - 293\text{K}) + (0.8) (5.67 \times 10^{-8} \text{ W/(m}^2 \text{ K}^4)) T_s^4$$

$$4.535 \times 10^{-8} T_s^4 + 12 T_s - 4116 = 0$$



By trial and error

$$T_s = 309 \text{ K} = 36^\circ\text{C}$$

(b) The ratio of the convective to radiative loss is

$$\frac{q_c}{q_r} = \frac{\bar{h}_c (T_s - T_\infty)}{\varepsilon \sigma T_s^4} = \frac{(12 \text{ W}/(\text{m}^2 \text{ K})) (309 \text{ K} - 293 \text{ K})}{(0.8)(5.67 \times 10^{-8} \text{ W}/(\text{m}^2 \text{ K}^4))(309 \text{ K})^4} = 0.46$$

### COMMENTS

Since the radiative and convective terms are of the same order of magnitude, neither one may be neglected without introducing significant error.

### PROBLEM 1.50

**Determine the power requirement of a soldering iron in which the tip is maintained at  $400^\circ\text{C}$ . The tip is a cylinder 3 mm in diameter and 10 mm long. Surrounding air temperature is  $20^\circ\text{C}$  and the average convective heat transfer coefficient over the tip is  $20 \text{ W}/(\text{m}^2 \text{ K})$ . Initially, the tip is highly polished giving it a very low emittance.**

### GIVEN

- Soldering iron tip
- Diameter ( $D$ ) = 3 mm = 0.003 m
  - Length ( $L$ ) = 10 mm = 0.01 m
- Temperature of the tip ( $T_t$ ) =  $400^\circ\text{C}$   
Temperature of the surrounding air ( $T_\infty$ ) =  $20^\circ\text{C}$   
Average convective heat transfer coefficient ( $\bar{h}_c$ ) =  $20 \text{ W}/(\text{m}^2 \text{ K})$   
Emittance is very low ( $\varepsilon = 0$ )

### FIND

The power requirement of the soldering iron ( $\dot{q}$ )

### ASSUMPTIONS

- Steady state conditions exist  
All power used by the soldering iron is used to heat the tip  
Radiative heat transfer from the tip is negligible due to the low emittance  
The end of the tip is flat  
The tip is at a uniform temperature

### SKETCH

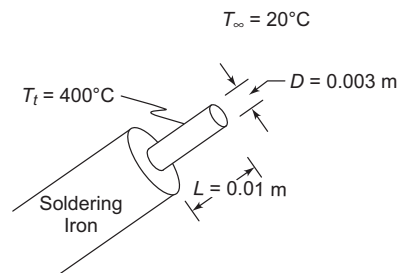

## SOLUTION

The power requirement of the soldering iron,  $\dot{q}$ , is equal to the heat lost from the tip by convection

$$q_c = \bar{h}_{co} A \Delta T = \bar{h}_c (\pi D^2/4 + \pi D L) (T_t - T_\infty) = \dot{q}$$
$$\dot{q} = 20 \text{ W}/(\text{m}^2 \text{ K}) \left[ \frac{\pi(0.003\text{m})^2}{4} + \pi(0.003\text{m})(0.01\text{m}) \right] (400^\circ\text{C} - 20^\circ\text{C})$$
$$\dot{q} = 0.77 \text{ W}$$

## PROBLEM 1.51

The soldering iron tip in Problem 1.50 becomes oxidized with age and its gray-body emittance increases to 0.8. Assuming that the surroundings are at 20°C determine the power requirement for the soldering iron.

**Problem 1.50:**

Determine the power requirement of a soldering iron in which the tip is maintained at 400°C. The tip is a cylinder 3 mm in diameter and 10 mm long. Surrounding air temperature is 20°C and the average convective heat transfer coefficient over the tip is 20 W/(m<sup>2</sup> K). Initially, the tip is highly polished giving it a very low emittance.

## GIVEN

- Soldering iron tip
- Diameter ( $D$ ) = 3 mm = 0.003 m
  - Length ( $L$ ) = 10 mm = 0.01 m
- Temperature of the tip ( $T_t$ ) = 400°C  
Temperature of the surrounding air ( $T_\infty$ ) = 20°C  
Average convective heat transfer coefficient ( $\bar{h}_c$ ) = 20 W/(m<sup>2</sup> K)  
Emittance of the tip ( $\epsilon$ ) = 0.8

## FIND

The power requirement of the soldering iron ( $\dot{q}$ )

## ASSUMPTIONS

- Steady state conditions exist
- All power used by soldering iron is used to heat the tip
- The surroundings of the soldering iron behave as a blackbody enclosure
- The end of the tip is flat

## SKETCH

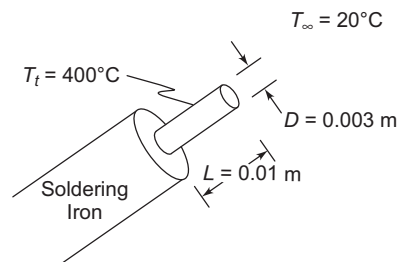

## PROPERTIES AND CONSTANTS

From Appendix 1, Table 5, the Stefan-Boltzmann constant ( $\sigma$ ) = 5.67 × 10<sup>-8</sup> W/(m<sup>2</sup> K<sup>4</sup>)

## SOLUTION

The rate of heat loss by convection, from Problem 1.50, is 0.77 W.

The rate of heat loss by radiation is given by Equation (1.17)

$$q_r = A_1 \varepsilon_1 \sigma (T_1^4 - T_2^4) = \left( \frac{\pi D^2}{4} + \pi DL \right) \varepsilon \sigma (T_t^4 - T_w^4)$$

$$q_r = \left[ \frac{\pi(0.003\text{ m})^2}{4} + \pi(0.003\text{ m})(0.01\text{ m}) \right] (0.8) [5.67 \times 10^{-8} \text{ W}/(\text{m}^2 \text{ K}^4)] [(673 \text{ K})^4 - (293 \text{ K})^4]$$

$$q_r = 0.91 \text{ W}$$

The power requirement of the soldering iron,  $\dot{q}$ , is equal to the total rate of heat loss from the tip. The total heat loss is equal to the sum of the convective and radiative losses

$$\dot{q} = q_c + q_r = 0.77 \text{ W} + 0.91 \text{ W} = 1.68 \text{ W}$$

### COMMENTS

Note that the inclusion of the radiative term more than doubled the power requirement for the soldering iron.

The power required to maintain the desired temperature could be provided by electric resistance heating.

### PROBLEM 1.52

**Some automobile manufacturers are currently working on a ceramic engine block that could operate without a cooling system. Idealize such an engine as a rectangular solid, 45 cm by 30 cm by 30 cm. Suppose that under maximum power output the engine consumes 5.7 liters of fuel per hour, the heat released by the fuel is 9.29 kWh per liter and the net engine efficiency (useful work output divided by the total heat input) is 0.33. If the engine block is alumina with a gray-body emissivity of 0.9, the engine compartment operates at 150°C, and the convective heat transfer coefficient is 30 W/(m<sup>2</sup> K), determine the average surface temperature of the engine block. Comment on the practicality of the concept.**

### GIVEN

Ceramic engine block, 0.45m by 0.3m by 0.3m  
 Engine gas consumption is 5.7 l/h  
 Heat released is 9.29 (kWh)/l  
 Net engine efficiency ( $\eta$ ) = 0.33  
 Emissivity ( $\varepsilon$ ) = 0.9  
 Convective heat transfer coefficient ( $hc$ ) = 30 W/(m<sup>2</sup> K)  
 Engine compartment temperature ( $T_c$ ) = 150°C = 423 K

### FIND

The surface temperature of the engine block ( $T_s$ )  
 Comment on the practicality

### ASSUMPTIONS

Heat transfer has reached steady state  
 The engine compartment behaves as a blackbody enclosure

## SKETCH

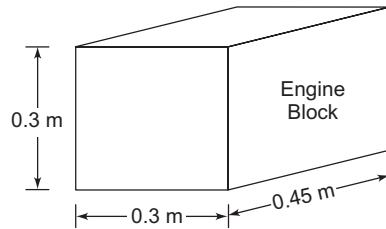

## PROPERTIES AND CONSTANTS

From Appendix 1, Table 5, the Stefan-Boltzmann constant ( $\sigma$ ) =  $5.67 \times 10^{-8} \text{ W}/(\text{m}^2 \text{ K}^4)$

## SOLUTION

The surface area of the idealized engine block is

$$A = 4 (0.45\text{m}) (0.3\text{m}) + 2(0.3\text{m})^2 = 0.72 \text{ m}^2$$

The rate of heat generation within the engine block is equal to the energy from the gasoline that is not transformed into useful work

$$\dot{q}_G = (1 - \eta) m_g h_g = (1 - 0.33) (5.71/\text{h}) (9.29 \text{ kWh}/1) = 35.5 \text{ kW}$$

For steady state conditions, the net radiative and convective heat transfer from the engine block must be equal to the heat generation within the engine block

$$q_{\text{total}} = q_r + q_c = \dot{q}_G$$

$$\dot{q}_G = A \varepsilon \sigma (T_s^4 - T_c^4) + \bar{h}_c A (T_s - T_c)$$

$$35.5 \text{ kW} = (0.72 \text{ m}^2) (0.9) \left( 5.67 \times 10^{-8} \text{ W}/(\text{m}^2 \text{ K}^4) \right) [T_s^4 - (423 \text{ K})^4] + (0.72 \text{ m}^2) \\ (30 \text{ W}/(\text{m}^2 \text{ K})) (T_s - 3.674 \times 10^{-8} T_s^4 + 21.6 T_s - 45656 = 0$$

By trial and error

$$T_s = 916 \text{ K} = 643^\circ\text{C}$$

## COMMENTS

The engine operates at a temperature high enough to burn a careless motorist.

Note that absolute temperature must be used in radiation equations.

Hot spots due to the complex geometry of the actual engine may produce local temperatures much higher than 916 K.

## PROBLEM 1.53

**A pipe carrying superheated steam in a basement at  $10^\circ\text{C}$  has a surface temperature of  $150^\circ\text{C}$ . Heat loss from the pipe occurs by radiation ( $\varepsilon = 0.6$ ) and natural convection [ $\bar{h}_c = 25 \text{ W}/(\text{m}^2 \text{ K})$ ]. Determine the percentage of the total heat loss by these two mechanisms.**

## GIVEN

Pipe in a basement

Pipe surface temperature ( $T_s$ ) =  $150^\circ\text{C} = 423 \text{ K}$

Basement temperature ( $T_\infty$ ) =  $10^\circ\text{C} = 283 \text{ K}$

Pipe surface emissivity ( $\epsilon$ ) = 0.6

Convective heat transfer coefficient ( $\bar{h}_c$ ) = 25 W/(m<sup>2</sup> K)

### FIND

The percentage of the total heat loss due to radiation and convection

### ASSUMPTIONS

The system is in steady state

The basement behaves as a blackbody enclosure at 10°C

### SKETCH

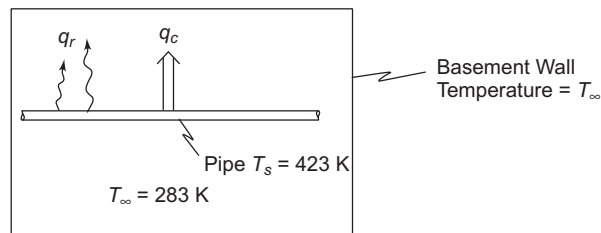

### PROPERTIES AND CONSTANTS

From Appendix 1, Table 5: the Stefan-Boltzmann constant ( $\sigma$ ) = 5.67 × 10<sup>-8</sup> W/(m<sup>2</sup> K<sup>4</sup>)

### SOLUTION

The rate of heat transfer from a gray-body to a blackbody enclosure, from Equation (1.17), is

$$q_r = A_1 \epsilon_1 \sigma (T_1^4 - T_2^4) = A \epsilon \sigma (T_s^4 - T_\infty^4)$$

$$\therefore \frac{q_r}{A} = (0.6) [5.67 \times 10^{-8} \text{ W}/(\text{m}^2 \text{ K}^4)] [(423 \text{ K})^4 - (283 \text{ K})^4]$$

$$\frac{q_r}{L} = 870 \text{ W/m}$$

The rate of heat transfer by convection, from Equation (1.10), is

$$q_c = \bar{h}_c A (T_s - T_\infty)$$

$$\therefore \frac{q_c}{A} = 25 \text{ W}/(\text{m}^2 \text{ K}) (423 \text{ K} - 283 \text{ K}) = 3500 \text{ W}/\text{m}^2$$

The total rate of heat transfer is the sum of the radiative and convective rates

$$\frac{q_{\text{total}}}{A} = \frac{q_r}{A} + \frac{q_c}{A} = 870 \text{ W}/\text{m}^2 + 3500 \text{ W}/\text{m}^2 = 4370 \text{ W}/\text{m}^2$$

The percentage of the total heat transfer due to radiation is

$$\frac{q_r/A}{q_{\text{total}}/A} \times 100 = \frac{870}{4370} \times 100 = 20\%$$

The percentage of the total heat transfer due to convection is

$$\frac{q_c/A}{q_{\text{total}}/A} \times 100 = \frac{3500}{4370} \times 100 = 80\%$$

**COMMENTS**

This pipe surface temperature and rate of heat loss are much too high to be acceptable. In practice, a layer of mineral wool insulation would be wrapped around the pipe. This would reduce the surface temperature as well as the rate of heat loss.

**PROBLEM 1.54**

**For a furnace wall, draw the thermal circuit, determine the rate of heat flow per unit area, and estimate the exterior surface temperature under the following conditions: the convective heat transfer coefficient at the interior surface is  $15 \text{ W}/(\text{m}^2 \text{ K})$ ; rate of heat flow by radiation from hot gases and soot particles at  $2000^\circ\text{C}$  to the interior wall surface is  $45,000 \text{ W}/\text{m}^2$ ; the unit thermal conductance of the wall (interior surface temperature is about  $850^\circ\text{C}$ ) is  $250 \text{ W}/(\text{m}^2 \text{ K})$ ; there is convection from the outer surface.**

**GIVEN**

A furnace wall

Convective heat transfer coefficient ( $\bar{h}_c$ ) =  $15 \text{ W}/(\text{m}^2 \text{ K})$

Temperature of hot gases inside furnace ( $T_g$ ) =  $2000^\circ\text{C}$

Rate of radiative heat flow to the interior of the wall ( $q_r/A$ ) =  $45,000 \text{ W}/\text{m}^2$

Unit thermal conductance of the wall ( $k/L$ ) =  $250 \text{ W}/(\text{m}^2 \text{ K})$

Interior surface temperature ( $T_{wi}$ ) is about  $850^\circ\text{C}$

Convection occurs from outer surface of the wall

**FIND**

- (a) Draw the thermal circuit
- (b) Rate of heat flow per unit area ( $q/A$ )
- (c) The exterior surface temperature ( $T_{wo}$ )

**ASSUMPTIONS**

Heat flow through the wall is one dimensional

Steady state prevails

**SKETCH**

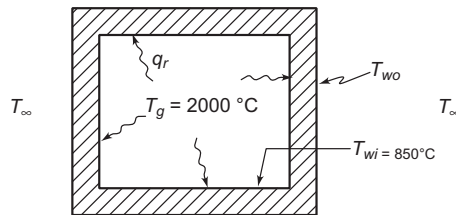

**SOLUTION**

The thermal circuit for the furnace wall is shown below

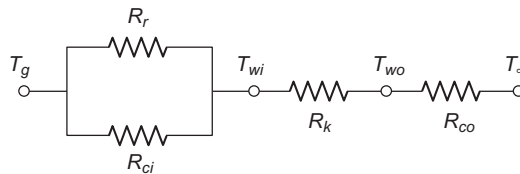

The rate of heat flow per unit area through the wall is equal to the rate of convective and radiative heat flow to the interior wall

$$\frac{q}{A} = \frac{q_r}{A} + \frac{q_c}{A} = \frac{q_r}{A} + \bar{h}_c (T_g - T_{wi})$$

$$\frac{q}{A} = 45,000 \text{ W/m}^2 + 15 \text{ W/(m}^2 \text{ K)} (2000^\circ\text{C} - 850^\circ\text{C}) = 62,250 \text{ W/m}^2$$

We can calculate the outer surface temperature of the wall by examining the conductive heat transfer through the wall given by Equation (1.2)

$$q_k = \frac{KA}{L} (T_{wi} - T_{wo})$$

$$\therefore T_{wo} = T_{wi} - \frac{q_k}{A} \frac{1}{k/L} = 850^\circ\text{C} - (62,250 \text{ W/m}^2) \left( \frac{1}{250 \text{ W/(m}^2 \text{ K)}} \right) = 601^\circ\text{C}$$

### COMMENTS

The corner sections should be analyzed separately since the heat flow there is not one dimensional.

### PROBLEM 1.55

**Draw the thermal circuit for heat transfer through a double-glazed window. Include solar energy gain to the window and the interior space. Identify each of the circuit elements. Include solar radiation to the window and interior space.**

### GIVEN

Double-glazed window

### FIND

The thermal circuit

### SKETCH

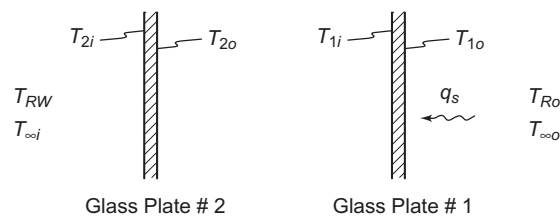

### SOLUTION

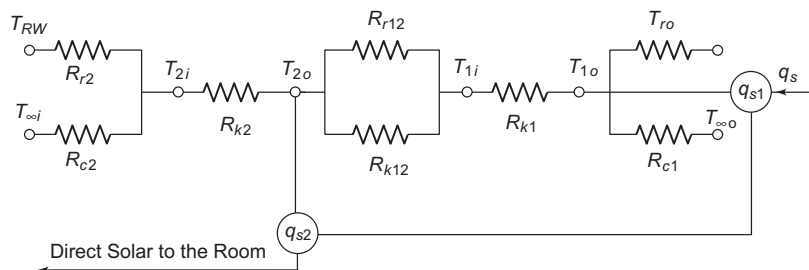

- where  $R_{r1}, R_{r12}, R_{r2}$  = Radiative thermal resistances  
 $R_{k1}, R_{k2}, R_{k12}$  = Conductive thermal resistances  
 $R_{c1}, R_{c2}$  = Convective thermal resistances  
 $T_{rw}, T_{ro}$  = Effective temperatures for radiative heat transfer  
 $T_{\infty}$  = Air temperatures  
 $T_{1i}, T_{1o}, T_{2i}$  = Surface temperatures of the glass  
 $q_{s1}, q_{s2}$  = Solar energy incident on the window panes

### PROBLEM 1.56

The ceiling of a tract house is constructed of wooden studs with fiberglass insulation between them. On the interior of the ceiling is plaster and on the exterior is a thin layer of sheet metal. A cross section of the ceiling with dimensions is shown below.

(a) The  $R$ -factor describes the thermal resistance of insulation and is defined by:

$$R\text{-factor} = L/k_{\text{eff}} = \Delta T/(q/A)$$

Calculate the  $R$ -factor for this type of ceiling and compare the value of this  $R$ -factor with that for a similar thickness of fiberglass. Why are the two different?

(b) Estimate the rate of heat transfer per square meter through the ceiling if the interior temperature is  $22^{\circ}\text{C}$  and the exterior temperature is  $-5^{\circ}\text{C}$ .

### GIVEN

Ceiling of a tract house, construction shown below  
 Inside temperature ( $T_i$ ) =  $22^{\circ}\text{C}$   
 Outside temperature ( $T_o$ ) =  $-5^{\circ}\text{C}$

### FIND

- (a)  $R$ -factor for the ceiling ( $RF_c$ ). Compare this to the  $R$ -factor for the same thickness of fiberglass ( $RF_{fg}$ ). Why do they differ?  
 (b) Rate of heat transfer ( $q/A$ )

### ASSUMPTIONS

Steady state heat transfer  
 One dimensional conduction through the ceiling  
 Thermal resistance of the sheet metal is negligible

### SKETCH

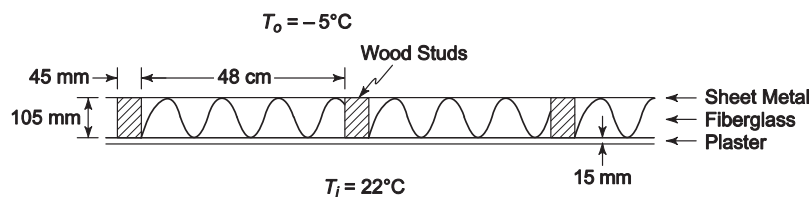

### PROPERTIES AND CONSTANTS

From Appendix 2, Table 11, the thermal conductivities of the ceiling materials are

Pine or fir wood studs ( $k_w$ ) =  $0.15 \text{ W/(m K)}$  at  $20^{\circ}\text{C}$

Fiberglass ( $k_{fg}$ ) =  $0.035 \text{ W/(m K)}$  at  $20^{\circ}\text{C}$

Plaster ( $k_p$ ) =  $0.814 \text{ W/(m K)}$  at  $20^{\circ}\text{C}$



## SOLUTION

The thermal circuit for the ceiling with studs is shown below

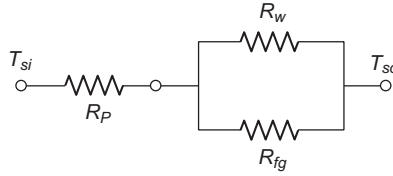

where  $R_p$  = thermal resistance of the plaster

$R_w$  = thermal resistance of the wood

$R_{fg}$  = thermal resistance of the fiberglass

Each of these resistances can be evaluated using Equation (1.4)

$$R_p = \frac{L_p}{A_{\text{wall}} k_p} = \frac{15 \times 10^{-3} \text{ m}}{(A_{\text{wall}})[0.814 \text{ W}/(\text{m K})]} = \frac{1}{A_{\text{wall}}} 0.0184 \text{ K m}^2/\text{W}$$

$$R_w = \frac{L_w}{A_w k_w} = \frac{105 \times 10^{-3} \text{ m}}{(A_w)[0.15 \text{ W}/(\text{m K})]} = \frac{1}{A_{\text{wall}}} 0.7 \text{ K m}^2/\text{W}$$

$$R_{fg} = \frac{L_{fg}}{A_{fg} k_{fg}} = \frac{105 \times 10^{-3} \text{ m}}{(A_{fg})[0.035 \text{ W}/(\text{m K})]} = \frac{1}{A_{\text{wall}}} 3 \text{ K m}^2/\text{W}$$

To convert these all to a wall area basis the fraction of the total wall area taken by the wood studs and the fiberglass must be calculated

$$\text{wood studs} = \frac{A_w}{A_{\text{wall}}} = \frac{45 \text{ mm}}{48 \text{ cm}} = 0.094$$

$$\text{fiberglass} = \frac{A_{fg}}{A_{\text{wall}}} = \frac{43.5 \text{ cm}}{48 \text{ m}} = 0.906$$

Therefore the resistances of the studs and the fiberglass based on the wall area are

$$R_w = \frac{1}{0.094 A_{\text{wall}}} 0.7 \text{ K m}^2/\text{W} = \frac{1}{A_{\text{wall}}} 7.45 \text{ K m}^2/\text{W}$$

$$R_{fg} = \frac{1}{0.906 A_{\text{wall}}} 3 \text{ K m}^2/\text{W} = \frac{1}{A_{\text{wall}}} 3.31 \text{ K m}^2/\text{W}$$

The  $R$ -Factor of the wall is related to the total thermal resistance of the wall by

$$RF_c = A_{\text{wall}} R_{\text{total}} = A_{\text{wall}} \left[ R_p + \frac{R_w R_{fg}}{R_w + R_{fg}} \right] =$$

$$0.0184 + \frac{(7.45)(3.31)}{7.45 + 3.31} \text{ K m}^2/\text{W} = 2.31 \text{ K m}^2/\text{W}$$

For 12 cm of fiberglass alone, the  $R$ -factor is

$$RF_{fg} = \frac{L}{k_{fg}} = \frac{12 \times 10^{-2} \text{ m}}{0.035 \text{ W}/(\text{m K})} = 3.43 \text{ K m}^2/\text{W}$$

The R-factor of the ceiling is only 67% that of the same thickness of fiberglass. This is mainly due to the fact that the wood studs act as a ‘thermal short’ conducting heat through the ceiling more quickly than the surrounding fiberglass.

(b) The rate of heat transfer through the ceiling is

$$\frac{q}{A} = \frac{\Delta T}{RF_c} = \frac{22^\circ\text{C} - (-5^\circ\text{C})}{2.31\text{K m}^2/\text{W}} = 11.69 \text{ W/m}^2$$

### COMMENTS

R-factors are given in handbooks. For example, *Mark’s Standard Handbook for Mechanical Engineers* lists the R-factor of a multi-layer masonry wall as  $6.36 \text{ Btu}/(\text{h ft}^2) = 20 \text{ W/m}^2$ .

### PROBLEM 1.57

**A homeowner wants to replace an electric hot-water heater. There are two models in the store. The inexpensive model costs \$280 and has no insulation between the inner and outer walls. Due to natural convection, the space between the inner and outer walls has an effective conductivity of 3 times that of air. The more expensive model costs \$310 and has fiberglass insulation in the gap between the walls. Both models are 3.0 m tall and have a cylindrical shape with an inner wall diameter of 0.60 m and a 5 cm gap. The surrounding air is at 25°C, and the convective heat transfer coefficient on the outside is 15 W/(m<sup>2</sup> K). The hot water inside the tank results in an inside wall temperature of 60°C.**

**If energy costs 6 cents per kilowatt-hour, estimate how long it will take to pay back the extra investment in the more expensive hot-water heater. State your assumptions.**

### GIVEN

- Two hot-water heaters
  - Height ( $H$ ) = 3.0 m
  - Inner wall diameter ( $D_i$ ) = 0.60 m
  - Gap between walls ( $L$ ) = 0.05 m
- Water heater #1
  - Cost = \$280.00
  - Insulation: none
  - Effective Conductivity between wall ( $k_{\text{eff}}$ ) =  $3(k_a)$
- Water heater #2
  - Cost = \$310.00
  - Insulation: Fiberglass
- Surrounding air temperature ( $T_\infty$ ) = 25°C
- Convective heat transfer coefficient ( $h_c$ ) = 15 W/(m<sup>2</sup> K)
- Inside wall temperature ( $T_{wi}$ ) = 60°C
- Energy cost = \$0.06/kWh

### FIND

The time it will take to pay back the extra investment in the more expensive hot-water heater

### ASSUMPTIONS

Since the diameter is large compared to the wall thickness, one-dimensional heat transfer is assumed. To simplify the analysis, we will assume there is no water drawn from the heater, therefore the inside wall is always at 60°C. Steady state conditions prevail.

## SKETCH

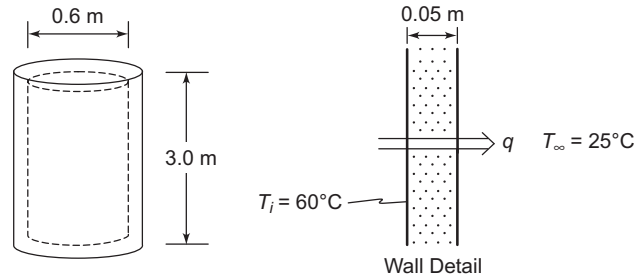

## PROPERTIES AND CONSTANTS

From Appendix, Table 11 and 27: The thermal conductivities are

fiberglass ( $k_i$ ) = 0.035 W/(m K) at 20°C

dry air ( $k_a$ ) = 0.0279 W/(m K) at 60°C

## SOLUTION

The areas of the inner and outer walls are

$$A_i = 2 \frac{\pi D_i^2}{4} + \pi D_i H = 2 \frac{\pi (0.6 \text{ m})^2}{4} + \pi (0.6 \text{ m}) (3 \text{ m}) = 6.22 \text{ m}^2$$

$$A_o = 2 \frac{\pi D_o^2}{4} + \pi D_o H = 2 \frac{\pi (0.7 \text{ m})^2}{4} + \pi (0.7 \text{ m}) (3 \text{ m}) = 7.37 \text{ m}^2$$

The average area for the air or insulation between the walls ( $A_a$ ) = 6.8 m<sup>2</sup>.

The thermal circuit for water heater #1 is

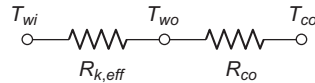

The rate of heat loss for water heater #1 is

$$q_1 = \frac{\Delta T}{R_{\text{total}}} = \frac{\Delta T}{R_{k,\text{eff}} + R_{co}} = \frac{T_{wi} - T_{\infty}}{\frac{L}{k_{\text{eff}} A_a} + \frac{1}{h_{\infty} A_{co}}}$$

$$q_1 = \frac{60^{\circ}\text{C} - 25^{\circ}\text{C}}{\frac{0.05 \text{ m}}{3[0.0279 \text{ W}/(\text{m K})](6.8 \text{ m}^2)} + \frac{1}{[15 \text{ W}/(\text{m}^2 \text{ K})](7.37 \text{ m}^2)}} = 361 \text{ W} = 0.361 \text{ kW}$$

Therefore the cost to operate water heater #1 is

$$\text{Cost}_1 = q_1 (\text{energy cost}) = 0.361 \text{ kW} (\$0.06/\text{kWh}) (24 \text{ h/day}) = \$0.52/\text{day}$$

The thermal circuit for water heater #2 is

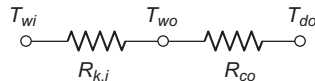

The rate of heat loss from water heater #2 is

$$q_2 = \frac{60^{\circ}\text{C} - 25^{\circ}\text{C}}{\frac{0.05 \text{ m}}{[0.035 \text{ W}/(\text{m K})](6.8 \text{ m}^2)} + \frac{1}{[15 \text{ W}/(\text{m}^2 \text{ K})](7.37 \text{ m}^2)}} = 160 \text{ W} = 0.16 \text{ kW}$$

Therefore the cost of operating water heater #2 is

$$\text{Cost}_2 = q_2 (\text{energy cost}) = 0.16 \text{ kW} (\$0.06/\text{kWh}) (24 \text{ h/day}) = \$0.23/\text{day}$$

The time to pay back the additional investment is the additional investment divided by the difference in operating costs

$$\text{Payback time} = \frac{\$310 - \$280}{\$0.52/\text{day} - \$0.23/\text{day}}$$

$$\text{Payback time} = 103 \text{ days}$$

### COMMENTS

When water is periodically drawn from the water heater, energy must be supplied to heat the cold water entering the water heater. This would be the same for both water heaters. However, drawing water from the heater also temporarily lowers the temperature of the water in the heater thereby lowering the heat loss and lowering the cost savings of water heater #2. Therefore, the payback time calculated here is somewhat shorter than the actual payback time.

A more accurate, but much more complex estimate could be made by assuming a typical daily hot water usage pattern and power output of heaters. But since the payback time is so short, the increased complexity is not justified since it will not change the bottom line—buy the more expensive model and save money as well as energy!

### PROBLEM 1.58

**Liquid oxygen (LOX) for the Space Shuttle can be stored at 90 K prior to launch in a spherical container 4 m in diameter. To reduce the loss of oxygen, the sphere is insulated with superinsulation developed at the US Institute of Standards and Technology's Cryogenic Division that has an effective thermal conductivity of 0.00012 W/(m K). If the outside temperature is 20°C on the average and the LOX has a heat of vaporization of 213 J/g, calculate the thickness of insulation required to keep the LOX evaporation rate below 200 g/h.**

### GIVEN

Spherical LOX tank with superinsulation

Tank diameter ( $D$ ) = 4 m

LOX temperature ( $T_{\text{LOX}}$ ) = 90 K

Ambient temperature ( $T_\infty$ ) = 20°C = 293 K

Thermal conductivity of insulation ( $k$ ) = 0.00012 W/(m K)

Heat of vaporization of LOX ( $h_{fg}$ ) = 213 kJ/kg

Maximum evaporation rate ( $\dot{m}_{\text{LOX}}$ ) = 0.2 kg/h

### FIND

The minimum thickness of the insulation ( $L$ ) to keep evaporation rate below 0.2 kg/h

### ASSUMPTIONS

The thickness is small compared to the sphere diameter so the problem can be considered one dimensional

Steady state conditions prevail

Radiative heat loss is negligible

## SKETCH

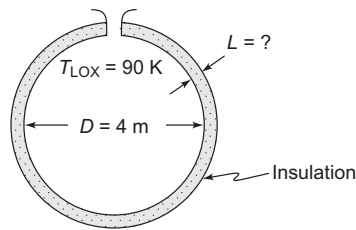

## SOLUTION

The maximum permissible rate of heat transfer is the rate that will evaporate 0.2 kg/h of LOX

$$q = \dot{m}_{Lox} h_{fg} = (0.2 \text{ kg/h}) (213 \text{ kJ/kg}) \left( \frac{\text{h}}{3600 \text{ s}} \right) \left( \frac{1000 \text{ J}}{\text{kJ}} \right) (\text{Ws/J}) = 11.8 \text{ W}$$

An upper limit can be put on the rate of heat transfer by assuming that the convective resistance on the outside of the insulation is negligible and therefore the outer surface temperature is the same as the ambient air temperature. With this assumption, heat transfer can be calculated using Equation (1.2), one dimensional steady state conduction

$$q_k = \frac{k A}{L} (T_{\text{hot}} - T_{\text{cold}}) = \frac{k \pi D^2}{L} (T_{\infty} - T_{\text{LOX}})$$

Solving for the thickness of the insulation ( $L$ )

$$L = \frac{k \pi D^2}{q_k} (T_{\infty} - T_{\text{LOX}}) = \frac{[0.00012 \text{ W/(m K)}] \pi (4 \text{ m})^2}{11.8 \text{ W}} (293 \text{ K} - 90 \text{ K}) = 0.10 \text{ m} = 10 \text{ cm}$$

## COMMENTS

The insulation thickness is small compared to the diameter of the tank. Therefore, the assumption of one dimensional conduction is reasonable.

## PROBLEM 1.59

**The heat transfer coefficient between a surface and a liquid is 60 W/(m<sup>2</sup>K). How many watts per square meter will be transferred in this system if the temperature difference is 10°C?**

## GIVEN

The heat transfer coefficient between a surface and a liquid ( $h_c$ ) = 60 W/(m<sup>2</sup>K)

Temperature difference ( $\Delta T$ ) = 10°C

## FIND

The rate of heat transfer in watts per square meter

## ASSUMPTIONS

Steady state conditions

Surface temperature is higher than the liquid temperature

### SKETCH

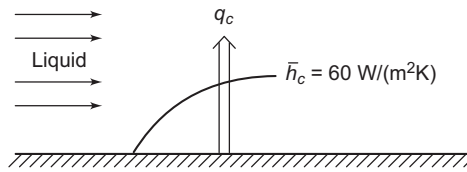

### SOLUTION

The rate of convective heat transfer per unit area ( $q_c/A$ ) is

$$\frac{q_c}{A} = \bar{h}_c \Delta T = 60 \text{ W}/(\text{m}^2\text{K}) \times 10^\circ\text{C} = 600 \text{ W}.$$

### PROBLEM 1.60

An ice chest (see sketch) is to be constructed from Styrofoam [ $k = 0.033 \text{ W}/(\text{m K})$ ]. If the wall of the chest is 5 cm thick, calculate its  $R$ -value in  $(\text{m}^2\text{K})/(\text{W-cm})$ .

### GIVEN

Ice chest constructed of Styrofoam,  $k = 0.033 \text{ W}/(\text{m K})$   
Wall thickness 5 cm

### FIND

(a)  $R$ -value of the ice chest wall

### ASSUMPTIONS

(a) One-dimensional, steady conduction

### SKETCH

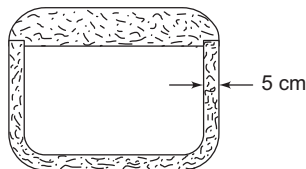

### SOLUTION

From Section 1.6 the  $R$ -value is defined as

$$R\text{-value} = \frac{\text{thickness}}{\text{thermal conductivity}}$$

$$R\text{-value} = \frac{5 \times 10^{-2} \text{ m}}{0.033 \text{ W}/(\text{m K})} = 1.51 (\text{m}^2\text{K})/\text{W}$$

From the problem statement, it is clear that we are asked to determine the  $R$ -value on a 'per-cm' basis. Dividing the above  $R$ -value by the thickness in cm, we get

$$R\text{-value} = \frac{1.51}{5} = 0.302 (\text{m}^2\text{K})/(\text{W-cm})$$

### PROBLEM 1.61

Estimate the  $R$ -values for a 5 cm-thick fiberglass board and a 2.5 cm-thick polyurethane foam layer. Then compare their respective conductivity-times-density products if the density for fiberglass is  $50 \text{ kg/m}^3$  and the density of polyurethane is  $30 \text{ kg/m}^3$ . Use the units given in Figure 1.27.

#### GIVEN

5 cm-thick fiberglass board, density =  $50 \text{ kg/m}^3$   
2.5 cm-thick polyurethane, density =  $30 \text{ kg/m}^3$

#### FIND

- (a)  $R$ -values for both
- (b) Conductivity-times-density products for both

#### ASSUMPTIONS

- (a) One-dimensional, steady conduction

#### SOLUTION

Ranges of conductivity for both of these materials are given in Figure 1.28. Using mean values we find:

fiberglass board  $k = 0.04 \text{ W/(m K)}$   
polyurethane foam  $k = 0.025 \text{ W/(m K)}$

For the 5 cm fiberglass we have

$t = 0.05 \text{ m}$   
 $k = 0.04 \text{ W/(m K)}$

From Section 1.6 the  $R$ -value is given by

$$R\text{-value} = \frac{\text{thickness}}{\text{thermal conductivity}} = \frac{0.050 \text{ m}}{0.04 \text{ W/(m K)}} = 1.25 \text{ (m}^2 \text{ K)/W}$$

and

$$\text{conductivity} \times \text{density} = (0.04 \text{ W/(m K)}) (50 \text{ kg/m}^3) = 2 \text{ (Wkg)/(Km}^4)$$

For the 2.5 cm polyurethane we have

$t = 0.025 \text{ m}$   
 $k = 0.025 \text{ W/(m K)}$

$$R\text{-value} = \frac{t}{k} = 1 \text{ (m}^2 \text{ K)/W}$$

$$\text{conductivity} \times \text{density} = (0.025 \text{ W/(m K)}) (30 \text{ kg/m}^3) = 0.75 \text{ (Wkg)/(Km}^4)$$

Summarizing, we have

	$R$ -value ( $\text{m}^2 \text{ K)/W}$	conductivity $\times$ density ( $\text{W kg)/(K m}^4$ )
2'' fiberglass board	1.25	2
1'' polyurethane foam	1	0.75

**PROBLEM 1.63**

**How many kilograms of ice can a 3-ton refrigeration unit produce in a 24-hour period? The heat of fusion of water is 330 kJ/kg.**

**A manufacturer in the US wants to sell a refrigeration system to a customer in Germany. The standard measure of refrigeration capacity used in the United States is the ‘ton’; a one-ton capacity means that the unit is capable of making about one ton of ice per day or has a heat removal rate of 3.52 kW. The capacity of the American system is to be guaranteed at three tons. What would this guarantee be in SI units?**

**GIVEN**

A three-ton refrigeration unit  
Heat of fusion of ice is 330 kJ/kg

**FIND**

- (a) Kilograms of ice produced by the unit per 24 hour period
- (b) The refrigeration unit capacity is the net value, i.e., it includes heat losses

**ASSUMPTIONS**

- (a) Water is cooled to just above the freezing point before entering the unit

**SOLUTION**

The mass of ice produced in a given period of time  $\Delta t$  is given by

$$m_{\text{ice}} = \frac{q\Delta T}{h_f}$$

where  $h_f$  is the heat of fusion and  $q$  is the rate of heat removal by the refrigeration unit. From Problem 1.65 we have  $q = 10,548 \text{ W}$ . Inserting the given values we have

$$m_{\text{ice}} = \frac{(10,548 \text{ W})(24 \text{ hr})}{(3.30 \times 10^5 \text{ J/kg})(\text{Ws})/\text{J}\left(\frac{\text{hr}}{3600\text{s}}\right)} = 2762 \text{ kg}$$

**PROBLEM 1.64**

**Explain a fundamental characteristic that differentiates conduction from convection and radiation.**

**SOLUTION**

Conduction is the only heat transfer mechanism that dominates in solid materials. Convection and radiation play important roles in fluids or, for radiation, in a vacuum. Under certain conditions, e.g., a transparent solid, radiation could be important in a solid.

**PROBLEM 1.65**

**Explain in your own words: (a) what is the mode of heat transfer through a large steel plate that has its surfaces at specified temperatures? (b) what are the modes when the temperature on one surface of the steel plate is not specified, but the surface is exposed to a fluid at a specified temperature.**

**GIVEN**

Steel plate with specified surface temperatures  
Steel plate with one specified temperature and another surface exposed to a fluid



**FIND**

- (a) Modes of heat transfer

**SKETCH**

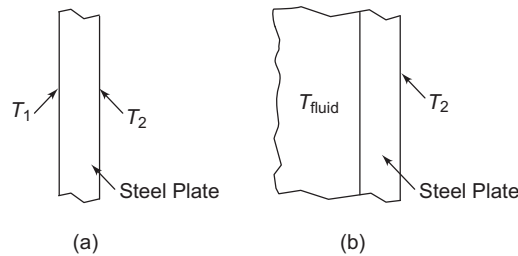

**SOLUTION**

- (a) Since the surface temperatures are specified, the only mode of heat transfer of importance is conduction through the steel plate  
(b) In addition to conduction to the steel plate, convection at the surface exposed to the fluid must be considered

**PROBLEM 1.66**

**What are the important modes of heat transfer for a person sitting quietly in a room?  
What if the person is sitting near a roaring fireplace?**

**GIVEN**

- Person sitting quietly in a room  
Person sitting in a room with a fireplace

**FIND**

- (a) Modes of heat transfer for each situation

**ASSUMPTIONS**

The person is clothed

**SOLUTION**

- (a) Since the person is clothed, we would need to consider conduction through the clothing, and convection and radiation from the exposed surface of the clothing.  
(b) In addition to the modes identified in (a), we would need to consider that surfaces of the person oriented towards the fire would be absorbing radiation from the flames.

**PROBLEM 1.67**

**Explain a fundamental characteristic that differentiates convection and radiation.**

**SOLUTION**

Conduction is the only heat transfer mechanism that dominates in solid materials. Convection and radiation play important roles in fluids or, for radiation, in a vacuum. Under certain conditions, e.g. a transparent solid, radiation could be important in a solid.

### PROBLEM 1.68

Describe and compare the modes of heat loss through the single-pane and double-pane window assemblies shown in the sketch below.

#### GIVEN

A single-pane and a double-pane window assembly

#### FIND

- (a) The modes of heat transfer for each
- (b) Compare the modes of heat transfer for each

#### ASSUMPTIONS

The window assembly wood casing is a good insulator

#### SKETCH

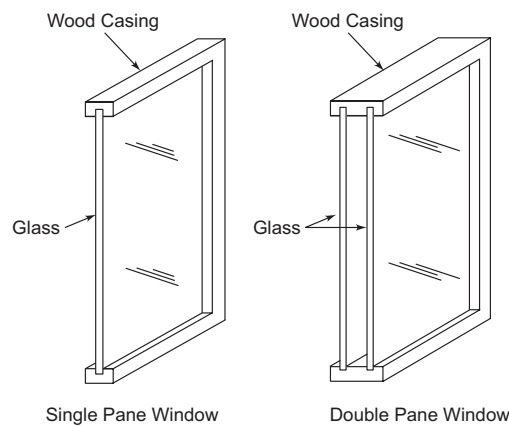

#### SOLUTION

The thermal network for both cases is shown above and summarizes the situation. For the single-pane window, we have convection on both exterior surfaces of the glass, radiation from both exterior surfaces of the glass, and conduction through the glass. For the double-pane window, we would have these modes in addition to radiation and convection exchange between the facing surfaces of the glass panes. Since the overall thermal network for the double-pane assembly replaces the pane-conduction with two-pane conductions plus the convection/radiation between the two panes, the overall thermal resistance of the double-pane assembly should be larger. Therefore, we would expect lower heat loss through the double-pane window.

### PROBLEM 1.69

A person wearing a heavy parka is standing in a cold wind. Describe the modes of heat transfer determining heat loss from the person's body.

#### GIVEN

Person standing in a cold wind wearing a heavy parka

#### FIND

- (a) The modes of heat transfer

#### SKETCH

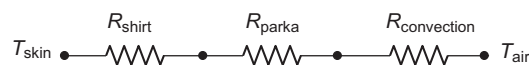

## SOLUTION

The thermal circuit for the situation is shown above. Assume that the person is wearing one other garment, i.e. a shirt, under the parka. The modes of heat transfer include conduction through the shirt and the parka and convection from the outer surface of the parka to the cold wind. We expect that the largest thermal resistance will be the parka insulation. We have neglected radiation from the parka outer surface because its influence on the overall heat transfer will be small compared to the other terms.

## PROBLEM 1.70

**Discuss the modes of heat transfer that determine the equilibrium temperature of the space shuttle Endeavor when it is in orbit. What happens when it reenters the earth's atmosphere?**

## GIVEN

Space shuttle Endeavor in orbit  
Space shuttle Endeavor during reentry

## FIND

(a) Modes of heat transfer

## SKETCH

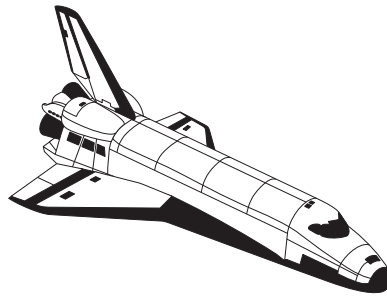

## SOLUTION

Heat generated internally will have to be rejected to the skin of the shuttle or to some type of radiator heat exchanger exposed to space. The internal loads that are not rejected actively, i.e., by a heat exchanger, will be transferred to the internal surface of the shuttle by radiation and convection, transferred by conduction through the skin, then radiated to space. These two paths of heat transfer must be sufficient to ensure that the interior is maintained at a comfortable working temperature.

During reentry, the exterior surface of the shuttle will be exposed to a heat flux that results from frictional heating by the atmosphere. In this case, it is likely that the net heat flow will be into the space shuttle. The thermal design must be such that during reentry the interior temperature does not exceed some safe value.