

Principles of Fiber Optic Transmission

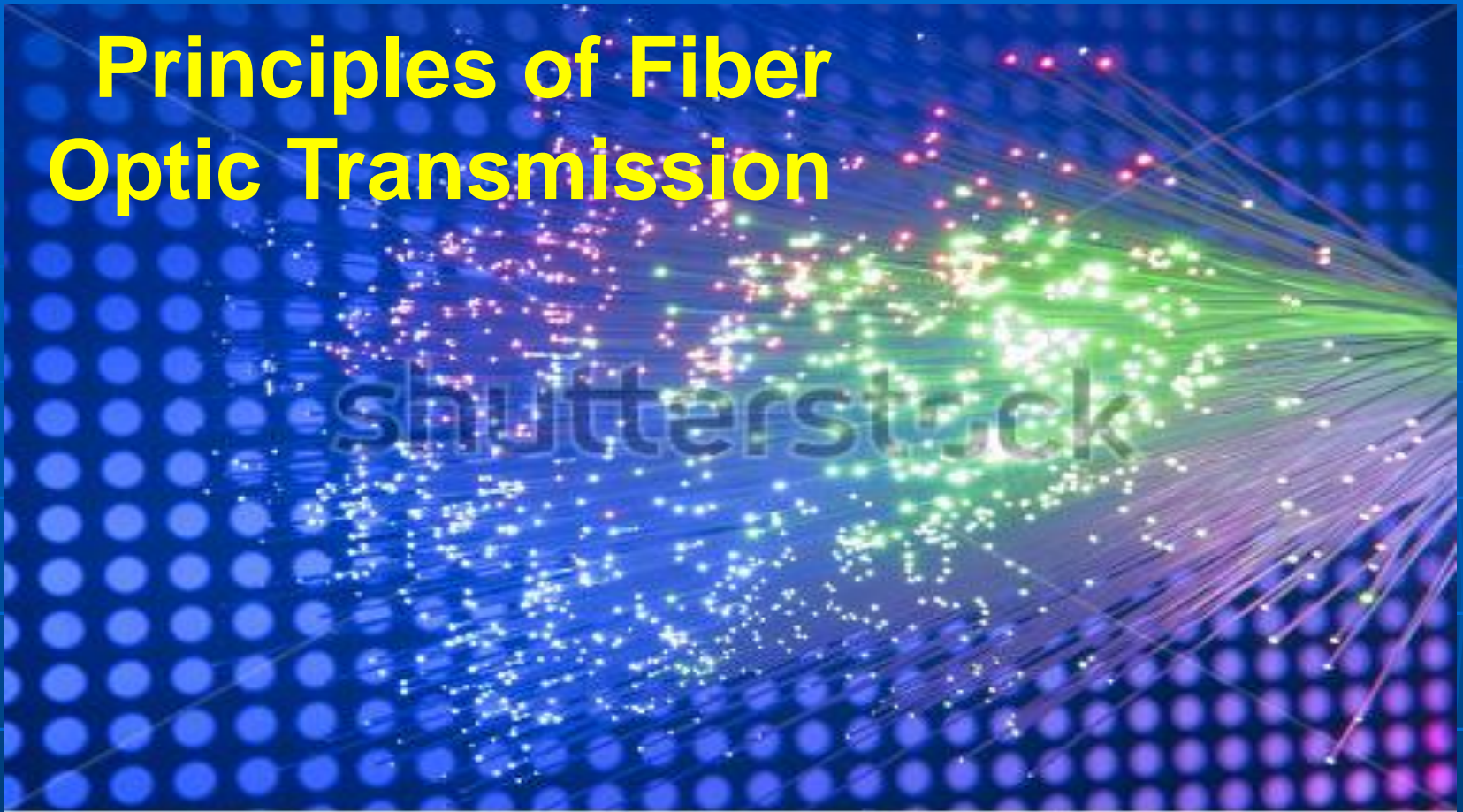

Lecturer :Huda Naji

University of Babylon
Information Technology college

In This Lecture

- Connectors
- What is Amplitude Modulation?
 - **Noise & Attenuation**
- Elements of an Optical Fiber communication
- Analog & Digital Transmission.
 - Analog
 - Digital
 - Analog Data Transmission
vs. Digital Data Transmission
 - Analog to Digital (A/D) Conversion
 - Sampling Rates
 - Quantizing Error
 - Digital to Analog (D/A) Conversion

Connectors

The connector is attached to the optical fiber and allows it to be mated to the transmitter or receiver to provide solid contact.

The connector must align the fiber end precisely with the light source or receiver to prevent signal loss.

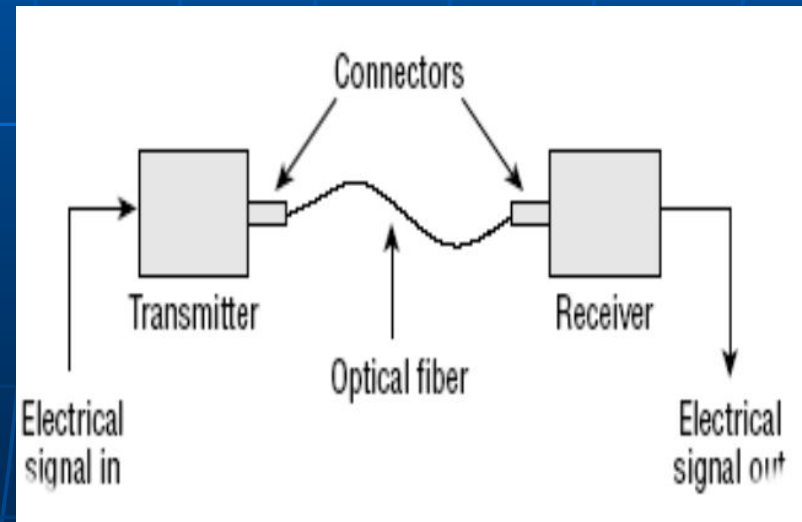

Elements of an Optical Fiber communication

Optical Fiber

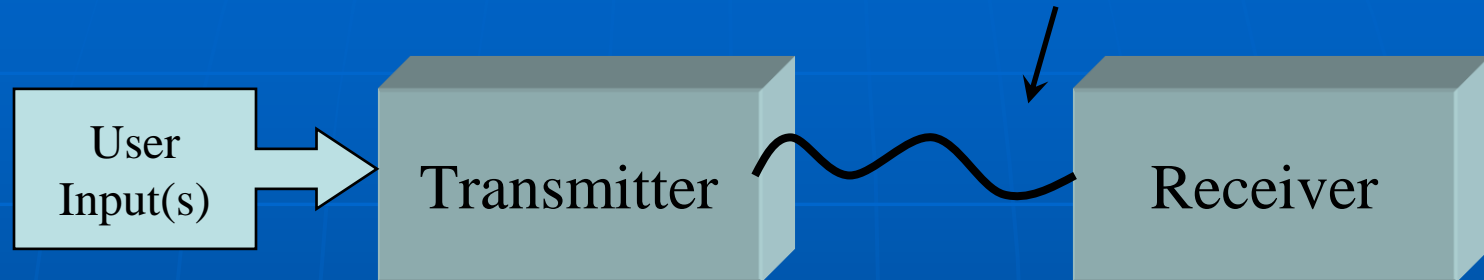

Electrical-to-Optical
Conversion

Optical-to-Electrical
Conversion

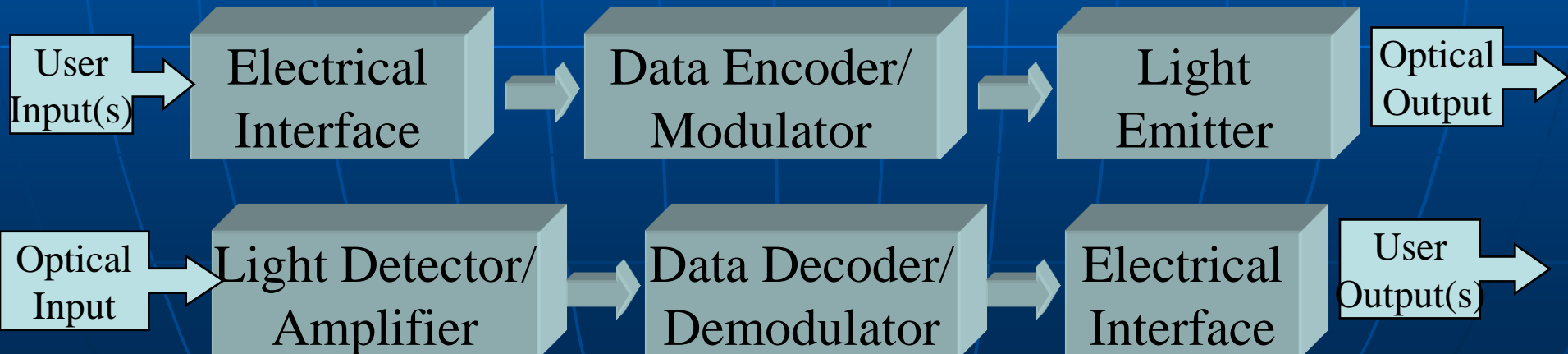

What is Amplitude Modulation?

One method used for converting electrical signals into light signals for transmission

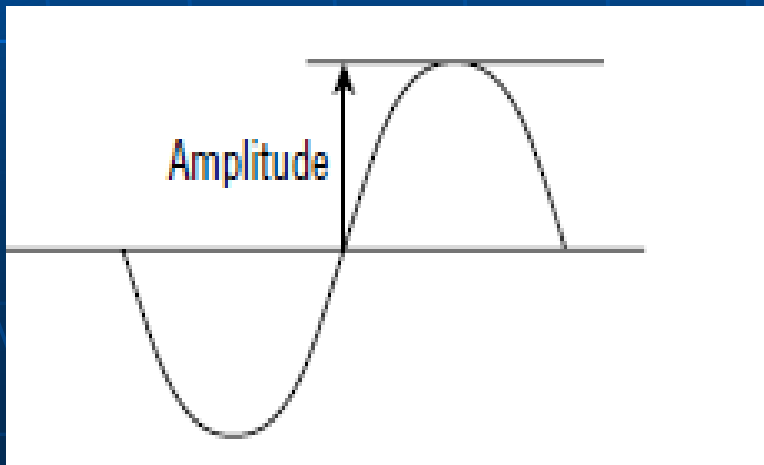
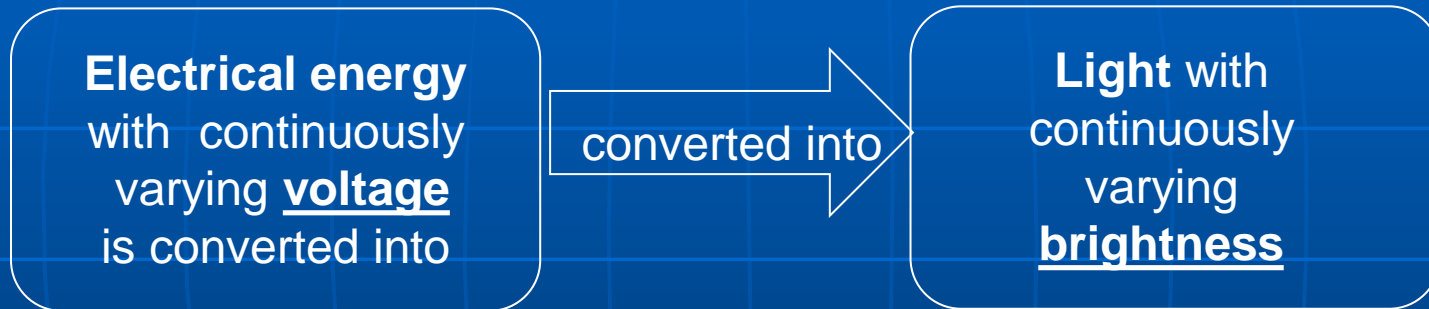

Amplitude modulation requires two components: a carrier and a signal that is imposed on the carrier—also known as the *intelligence*—to change it in some way

Amplitude modulation requires two components: a carrier and a signal that is imposed on the carrier—also known as the *intelligence*—to change it in some way

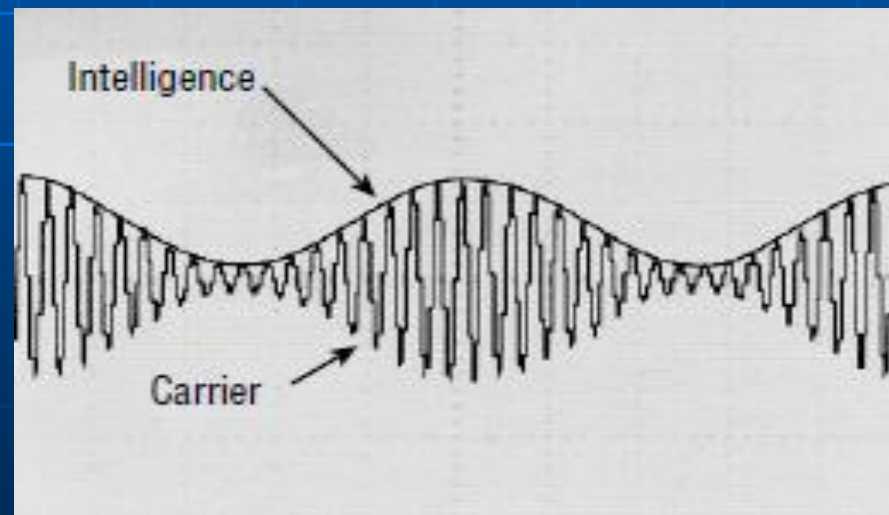

Noise & Attenuation

- Amplitude modulation suffers from two problems that can affect the quality of the signal:
 - attenuation and noise
 - **Noise** : can be considered data without meaning; that is, data that is not being used to transmit a signal, but is simply produced as an unwanted by-product of other activities.
 - **Attenuation** : *Attenuation* is a measure of how much a signal weakens as it travels through a medium.

Analog & Digital Transmission.

Signaling amounts to communicating information. The information being communicated can take one of two forms—*analog* or *digital*:

• ***Analog*** information changes continuously and can take on many different values. An analog clock's hands move constantly, displaying time on a continuous scale.

• ***Digital*** information is characterized by discrete states. A light bulb, for example, is on or off. A digital clock represents the time in one-minute intervals and doesn't change its numbers again until the next minute. A digital clock can represent exact minutes but not the seconds that pass in between.

ANALOG

- **ANALOG DATA**

For example, telephones take sound vibrations and turn them into electrical vibrations of the same shape before they are transmitted over traditional telephone lines. Radio wave transmissions work in the same way.

Computers, which handle data in digital form, require modems to turn signals from digital to analog before transmitting those signals over communication lines such as telephone lines that carry only analog signals. The signals are turned back into digital form (demodulated) at the receiving end so that the computer can process the data in its digital format.

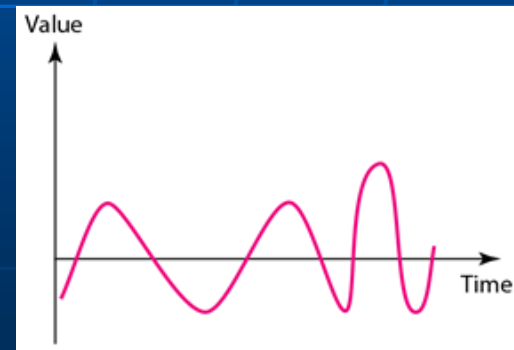

DIGITAL

■ DIGITAL DATA

This is the principle behind compact discs (CDs). The music itself exists in an analog form, as waves in the air, but these sounds are then translated into a digital form that is encoded onto the disk.

- When you play a compact disc, the CD player reads the digital data, translates it back into its original analog form, and sends it to the amplifier and eventually the speakers.
- Internally, computers are digital because they consist of discrete units called bits that are either on or off. But by combining many bits in complex ways, computers simulate analog events. In one sense, this is what computer science is all about.

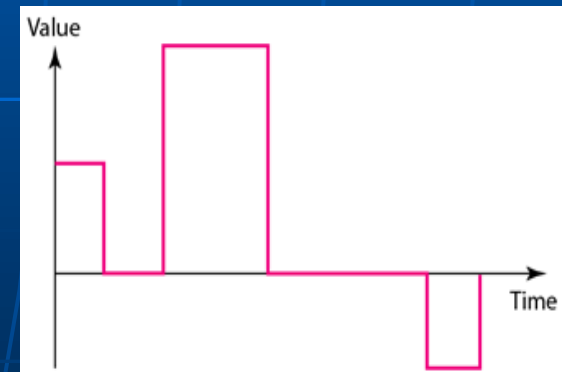

Analog Data Transmission vs. Digital Data Transmission

A digital signal is superior to an analog signal because it is more robust to noise and can easily be recovered, corrected and amplified. For this reason, the tendency today is to change an analog signal to digital data.

Analog to Digital (A/D) Conversion

In A/D conversion, the smooth, continuously variable analog signal is translated into a digital signal that carries the same information.

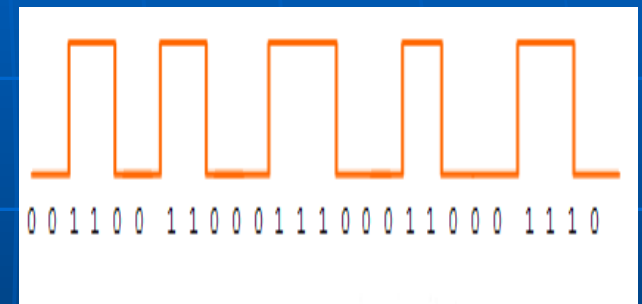
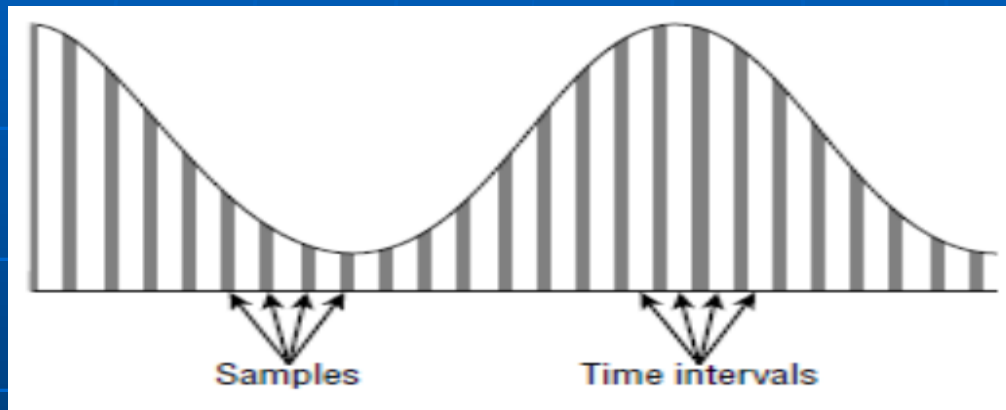

There are two factors that affect the quality of the digital sample: sample rate and quantizing error:

- 1- Sample Rate
- 2- Quantization Error

Sampling Rates

When an analog signal is Digitized, any information between the samples is lost so instead of a smooth transition over time, the digital information jumps from one voltage to the next in the signal.

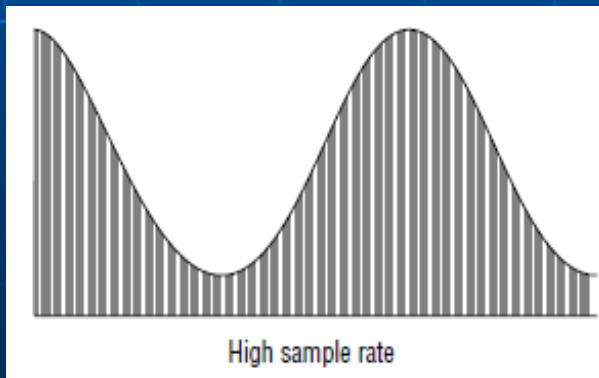
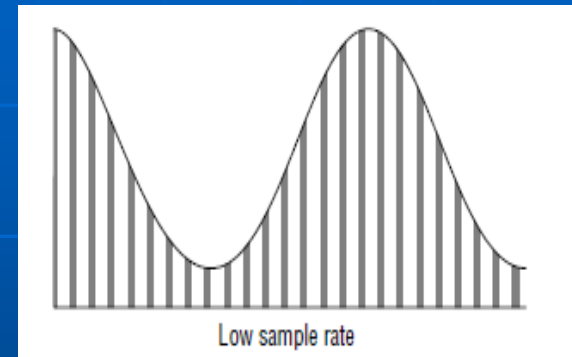

To smooth out the transitions and retain more of the information from the original analog signal, more samples must be taken over time. The higher the sampling rate, the more accurately the **original analog signal can be digitized.**

Quantizing Error

- Quantizing error is caused by the inability of a binary number to capture the exact voltage of a digital sample

Because an analog signal is infinitely variable, the sample's voltage could be any number within a specified range. If the binary number used to represent the voltage does not have enough bits, it cannot represent the voltage accurately

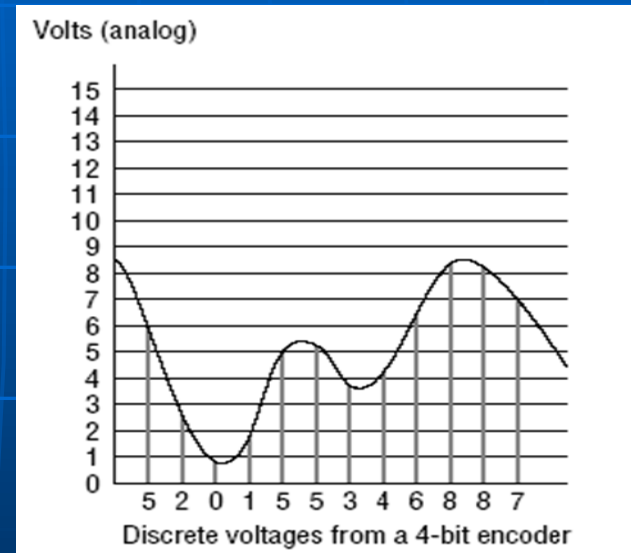

Digital to Analog (D/A) Conversion

- When digital data is converted to analog, two processes take place
 - Digital-to-Analog converter converts each sequential binary sample to a proportional voltage.
 - The steps between each digital sample must be smoothed out to provide a transition from one voltage to another

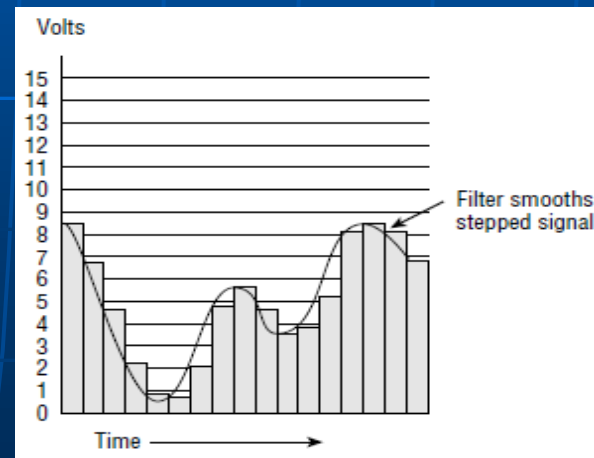
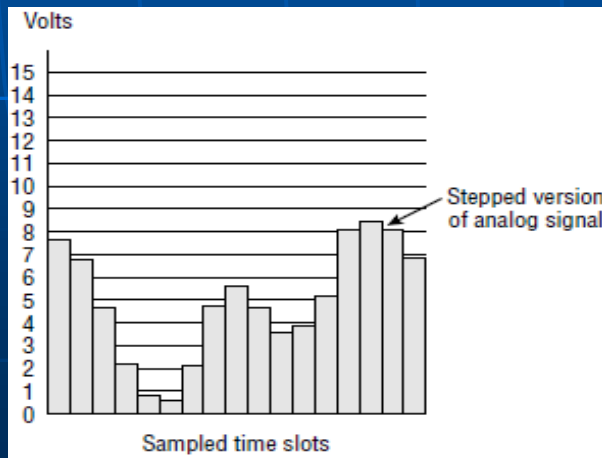

Thank you